

Isaac_{HD}

Multi-Function Leak Tester



User's Guide

Ver. 4.20

This page has been left blank intentionally.

For Your Safety

Install all equipment according to local safety codes.

Here are some additional safety guidelines when working with the Isaac or iKit leak tester:

- Wear eye protection when working with compressed gas.
- Beware that hazardous voltages could be present inside the enclosure.
- Only when you understand the procedure, and you know exactly how to complete the task, should you attempt any maintenance procedure discussed in this guide.



Warning! Disconnect power before removing cover or fuse holder



Caution! Equipment requires clean-dry supply air. Non-compliance may void warranty.



THREE YEAR LIMITED WARRANTY

Zaxis, Inc. Limited Warranty

ZAXIS INC. products are manufactured to a very high standard, however when located in physically hostile environments or when operated under non-specification voltage or pressure conditions, warranty may be voided. Please refer to your user manual for more detailed information.

ZAXIS INC., therefore, warrants only as follows: Supply clean dry air only to the unit.

Each unit is identified by serial number in a permanent record of the company. If at any time with-in three years after any ZAXIS INC. product has been shipped to a customer (user), it fails to perform according to ZAXIS INC. literature, the product, with written explanation of the problem, may be returned, freight prepaid, to ZAXIS INC. for examination, repair or replacement at ZAXIS INC. expense (labor and material). All such returns must have prior ZAXIS INC. customer service authorization before returning. If, upon examination, ZAXIS INC. determines that abusive practices, non-filtered and dried air or destructive environment of operation or a combination of these factors is responsible for improper performance of the product, all labor and materials costs involved shall be at the expense of the customer.

ZAXIS INC. is not liable for special, indirect or consequential damages that may result from use, failure or malfunction of the product and any recovery against ZAXIS INC. may not be greater than the purchase price paid for the product.

No person is authorized to change the terms of this warranty.

Introduction:

The Isaac HD Multi-Function Leak Tester is the newest product from Zaxis, designed to meet today's quality assurance demands.

The compact size of the Isaac enables it to be used near fixtures and operators utilizing a small footprint of bench top space. By reducing the internal and connection volume the test sensitivity increases, and test times can be decreased. The small internal volume combined with integrated sensors and a 24bit analog to digital converter allow Zaxis to offer a leak tester with the highest sensitivity on the market. The Isaac is available for pressure or vacuum decay, mass flow, burst, pressure cracking, sealed component (chamber), and custom test sequencing applications. The Isaac can be configured from one to four test channels in a sequential or concurrent configuration depending upon applications.

This guide covers the standard **Isaac HD and **i-Kit HD** leak testers. All of the current functions and features are described in this manual. Your tester could differ in installed features. Check the additional test types section of this guide for application notes about your tester.**

Safety and Emissions:



Operating Environment Conditions:

Indoor use only

- Operating temperature range: 5-40° C
- Maximum relative humidity: 80%
- Main supply voltage: 120 V +/-10%, 2A ~ 60 Hz
Or 230 V +/-10%, 2A ~ 50Hz
- Altitude: up to 2000 meters
- Supply Air Pressure: 8.3 bar max. (unless otherwise specified)
Supply air must be clean and dry.
(10-micron filtration minimum, 5-micron recommended)

Physical Description:



Font Panel



1. **Touch Screen Interface (TSi)** - The liquid crystal touch screen display is the primary control of the leak tester.
2. **Abort Button / Fail Indicator Light / Retest Button** - Red LED indicator marked with an 'X'.
3. **Start Button/Pass Indicator Light** - Green LED indicator marked with a '✓'.
4. **Test Ports** - Each port is a 1/8"-27 F NPT female threads. This is where the DUT (device under test) is attached. Test port positioning will vary by model.
5. **Tilt-up feet** – The position of the tester can be raised by rotating the tilt-up feet into position.
6. **USB** – USB 'A' port for data collection and program storage.

Rear Panel

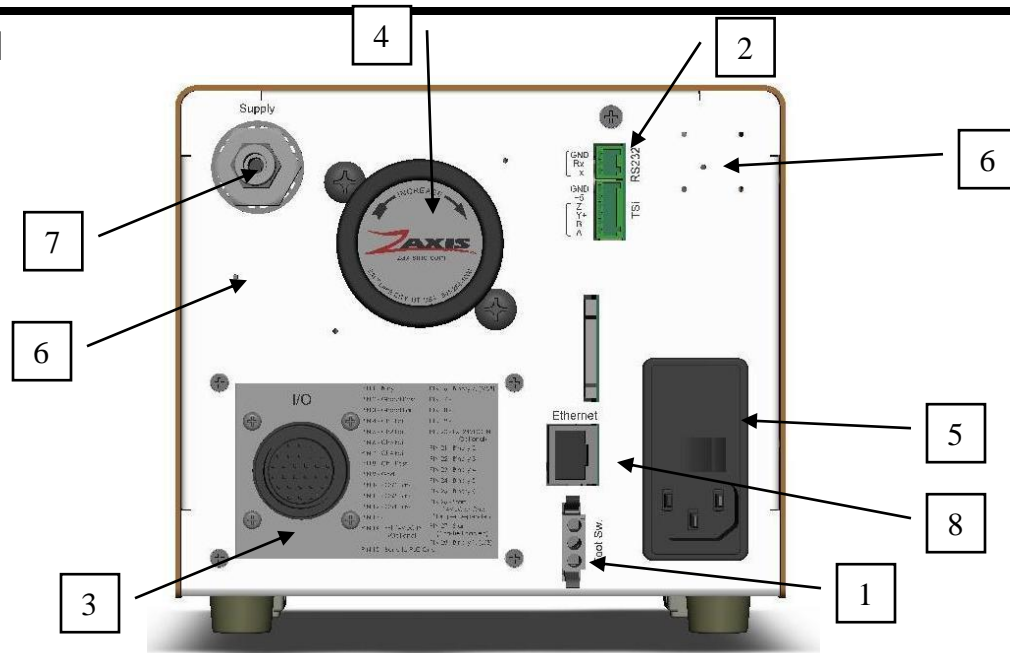

1. **Foot Switch Connector:** For starting a test. Any closed contact switch may be used to start a test by shorting pins 1 & 3
Mating Conn. & Pins – Tyco Electronics 1-480305-0 ([Digi-Key A1400-ND](#)), 60618-1 ([Digi-Key A1422-ND](#))
2. **Serial Output:** Connection for interfacing Isaac to computers or printers. ([Wiring](#)) Phoenix Contact 1881338 (Digi-key 277-1431-ND)
3. **Option Space:** This space is used for Fixture outputs (pneumatic) or I/O connection (shown)([Wiring](#))
If the I/O space is filled clamps will be in the secondary air connection location.
4. **Pressure Regulator:** Controls the air pressure applied to the product under test.
5. **Power Entry Module:** This component includes the power cord socket, on/off switch, and the fuse holder. Power entry is capable of a range of 109-255~VAC. 2A Fuse ([Service instructions](#))
6. **Secondary Air Connections:** These positions have multiple uses; Flow control for ramping burst/crack pressure, coupling or pilot air entry, or secondary test air supply. See the Quick Start shipped with the tester for details.
7. **Supply:** (Air or other test gases) Connection is 1/8"-27 NPT Female Supply gas must be **clean and dry**.
8. **Ethernet Connector:** ASCII communication, (data output and command string input.) HDe and iKit HDe models additional have the Ethernet I/P Communication Protocol. For details see the Ethernet I/P supplement guide.

Additional items may be installed on the rear panel, see the quick start guide shipped with the tester for additional details.

i-Kit rear panel

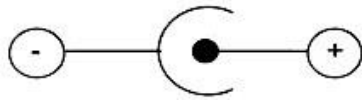
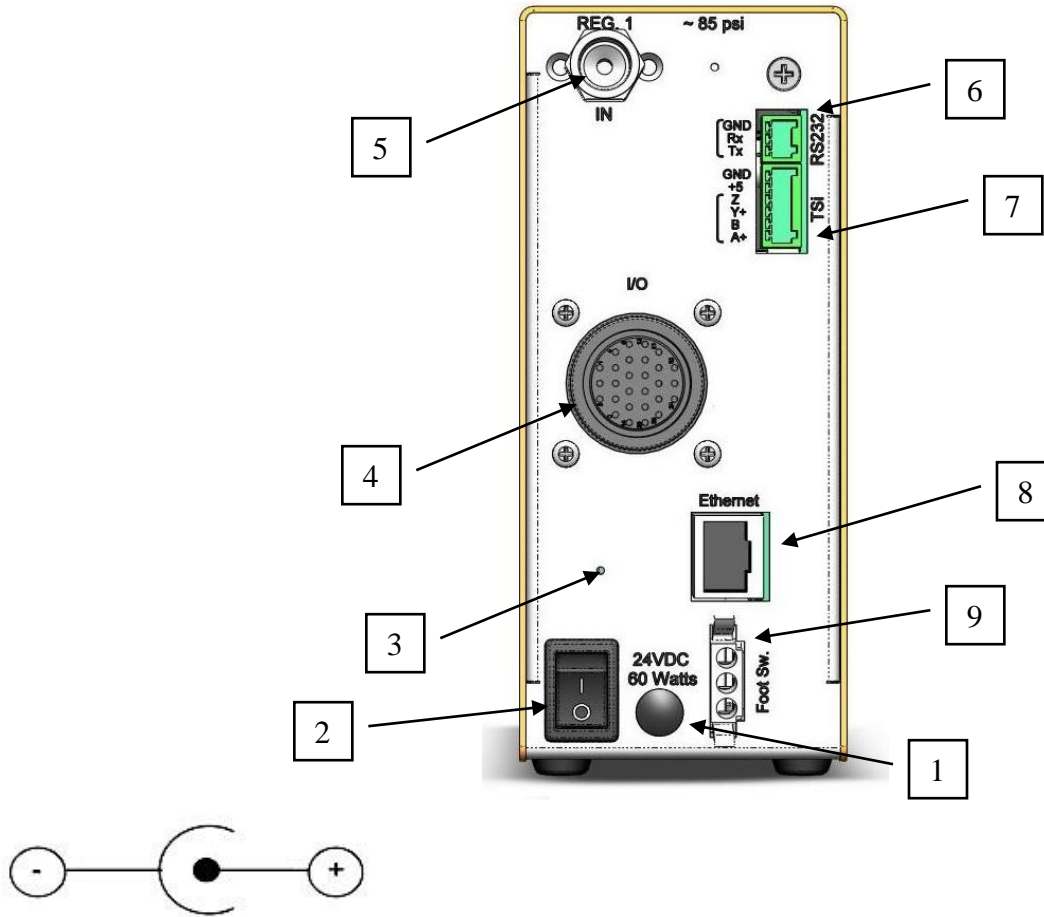

1. **Power Entry Connector**, Supply is +24VDC 60watts (Mating connector S760K-Switchcraft)
2. **Power Switch**
3. **Rear Test Port (optional)**
4. **I/O Interface Connection** ([Wiring Chart](#))
5. **Test Pressure Supply**, (Air or other test gas) Connection is 1/8"-27 F NPT (Similar to R1/8 BSPT British Standard Pipe Thread) Supply gas must be clean and dry.
6. **RS232 connector** ([wiring chart](#)) Phoenix Contact 1881338 (Digi-key 277-1431-ND)
7. **TSi, Touch Screen Interface** connector, the i-kit can be operated with or without the TSi attached.
8. **Ethernet Port**, AS ASCII communication, (data output and command string input.) HDe and iKit HDe models additional have the Ethernet I/P Communication Protocol. For details see the Ethernet I/P supplement guide.
9. **Footswitch connector**, For starting a test. Any closed contact switch may be used to start a test by shorting pins 1 & 3.

Mating Conn. & Pins – Tyco Electronics 1-480305-0 ([Digi-Key A1400-ND](#)), 60618-1 ([Digi-Key A1422-ND](#))

Control Screens:

Isaac^{HD}

Multi-Function Leak Tester

Serial # 4152-20M1

Color TSi Firmware Rev. 4.20

IsaacHD Firmware Rev. 4.20

Copyright 2020 - Zaxis, Inc.
(801) 264-1000 www.zaxisinc.com



Buttons at the bottom of the TSi display allow the user to navigate through the setup screens.



(Run Mode) – From any setup screen, press this button to change to the run mode, to begin testing.



(Program) - The program screens contain the parameters of the test (timers and Limits), the number of channels being tested, and the clamp valves timer configuration.



(Units) - Engineering units and the displayed sensor resolution.



(Calibrate) - Access to the calibration of Pressure, Vacuum, and Flow Sensors.



(Options) - The menu screen has eight options: (1) Touchscreen Calibration (2) Clock (3) I/O Setup (4) Data Logging (5) Lock tester (6) Change PIN (7) Serial Port (8) Ethernet Settings. Each screen is described later in the setup section.



(About) - The "About" screen lists the firmware revision level for the TSi and Isaac, serial number, as well as contact information for Zaxis.

The INFO button will show the following information.

Serial # 3052-20M2
Color TSi Firmware Rev. 4.20
IsaacHD Firmware Rev. 4.20
Tester Type: Pressure Decay
Regulator Type: Electronic
Pressure Range: 0-30



Data input

Two input screens are used throughout Isaac's setup and operation; they are the Numeric and Alpha-Numeric Keypad screens. The Numeric Keypad screen is used to input values for timer and limit fields. The Alpha-Numeric Keypad screen is used in fields such as the program name field.

Examples of each are shown below.

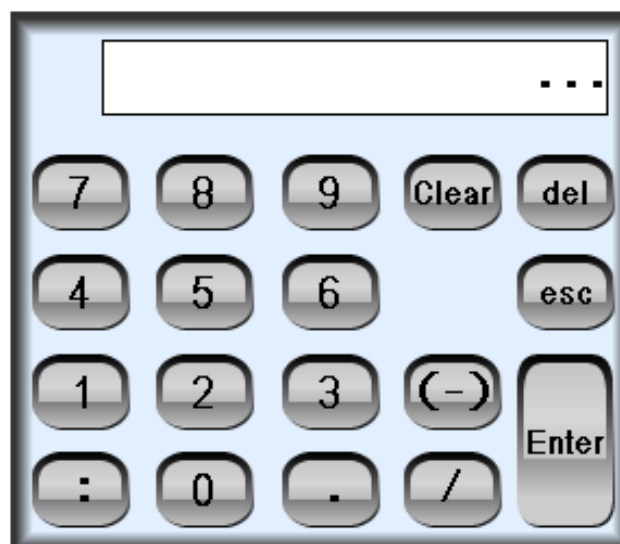

Note:

Pressing the 'shift' key changes the case.



Run Mode

There are two run screens available to choose from: Large Numeric and Graph Screen. These screens will slightly differ in single-channel and multichannel models



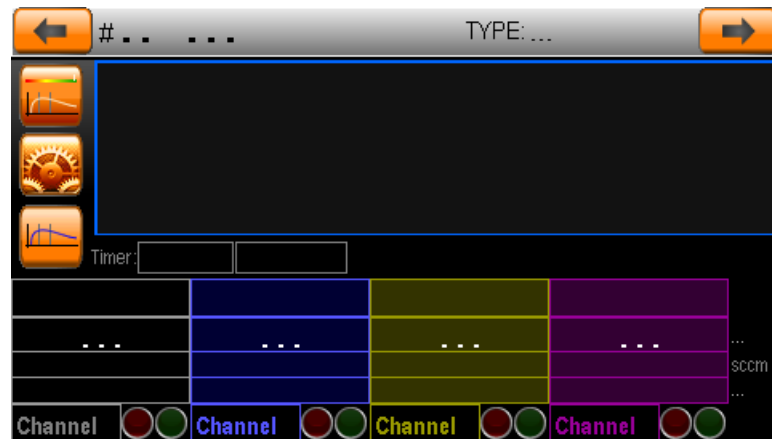

Run Screen Graphics



Return to the setup screens.



Cycle between the run screen selections. (Graph, Numeric)



Clear the previous test graph traces from the screen. (Graph only)



Change to Program Number. (Decrement)



Change to Program Number. (Increment)

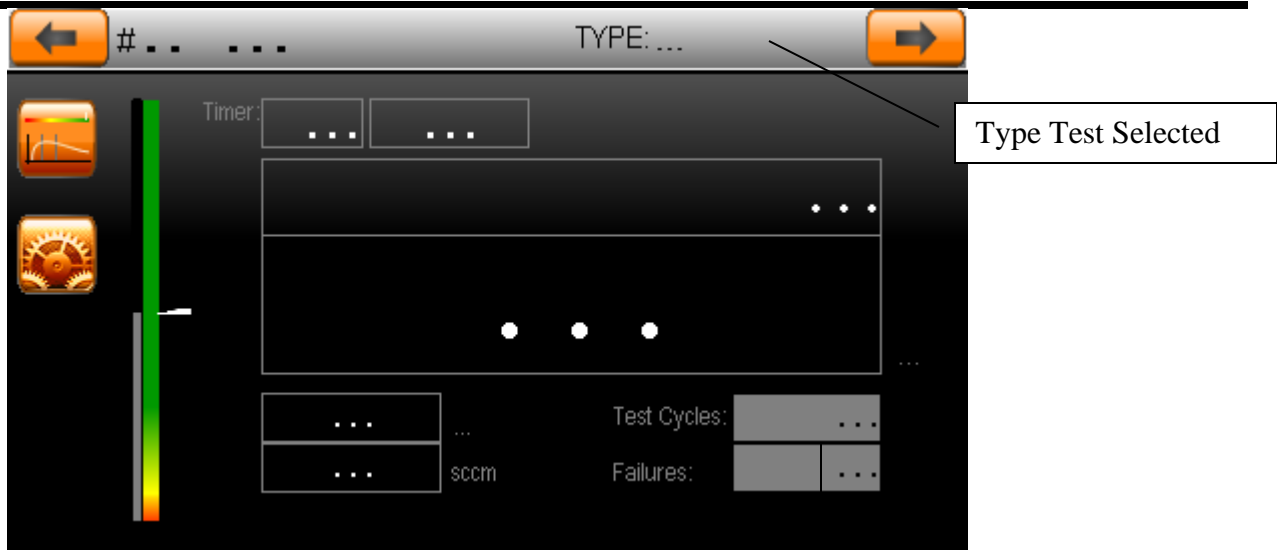

Touching the counters will open a menu to allow the values to be zeroed.

Bar Graphics

The '**BAR**' run screen shows the relevant test values at a graphical glance.

The timer bar is a graphical representation of the step time. Each step will reset the bar to full height to correspond the step time.



During the **Fill** and **Settle** steps the center of the graph equals the set test pressure value. The top of the graph is + tolerance and the bottom of the graph is the - tolerance. During the **Test** step the top of the bar is zero decay and the bottom of the bar is the reject level. The white arrow shows the live value.

Graph Screen Scaling

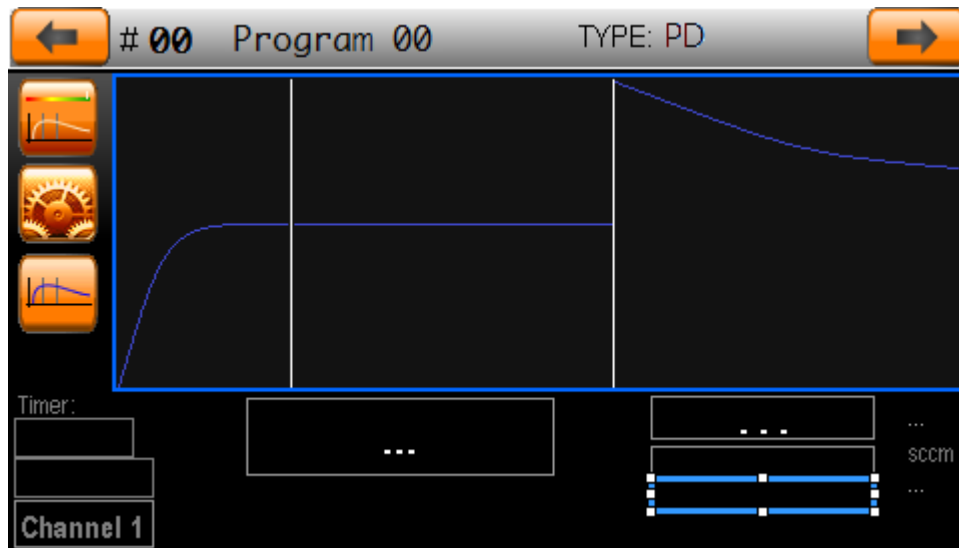

The graph is painted on the screen in two scales. Fast Fill, Fill, and Settle are scaled by the test pressure and plus/minus tolerances. The Test step is scaled to the test limits.

For example, if the test pressure were 10.0psi and the \pm tolerances were 0.5 psi, the test pressure would be center in the horizontal, the top of the screen would be 10.5psi and the bottom of the screen would be 9.5psi.

If the test limits were 0.050psi the top horizontal would be zero decay and the bottom of the screen would be 0.050psi decay.

Setup Screens

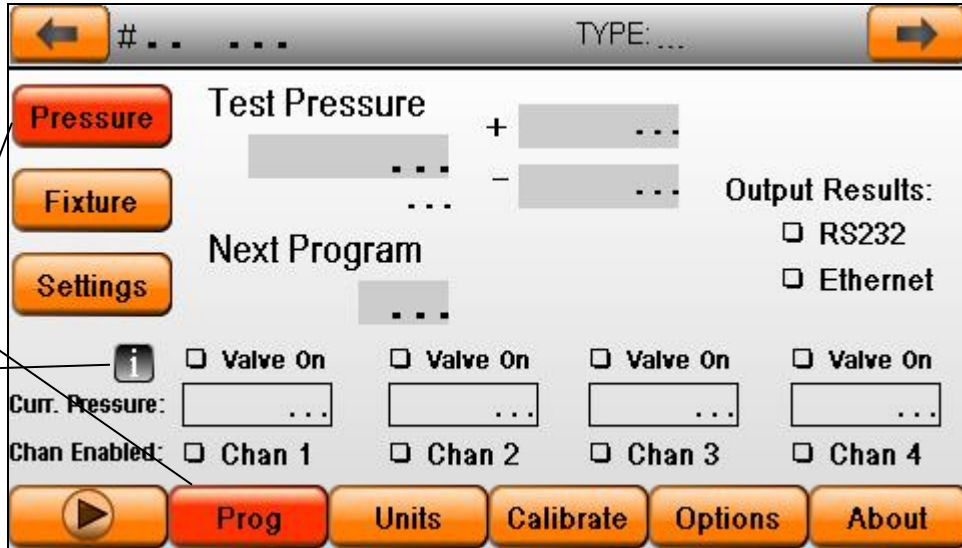

The darkened button shows the active selection.

Press the 'i' to get more information about the settings

Setting Test Pressure

To set the test pressure, press the data field and enter the test pressure value on the keypad. For machines with the electronic regulator option see below for test pressure setting instructions.

To Verify Test Pressure

To verify the manual regulator is set correctly, cap the test port and check the 'Valve On' box above the appropriate channel. The current pressure will be displayed in the box.

Units with the electronic regulator will automatically adjust during the test.

Pressure Tolerance ±

The amount of tolerance both plus and minus can be entered in the data fields to the right of the test pressure. This is the amount of tolerance on the test pressure. During the Fill step a value outside the boundaries will result in a Hi or LO pressure error. During the Settle step, any pressure value outside of the boundary will result in an error.

Test Channel Enable/Disable

To enable/disable channels (multi-channel models) check boxes enable/disable channels to be tested. Sequential models will only allow one selection.

Next Program (Sequencing Linking Tests)

To link programs together enter the number of the next program to jump to upon a pass result of the current test. Entering same number as the current test will not loop the tests. A test failure will cancel the jump to the next program.

Loops (Repeated Tests) To run the same program repeatedly enter a value. A value of 10 will run the test 10 times with no pause between tests.

Setup Screens



Setting Test pressure (Electronic Regulator)

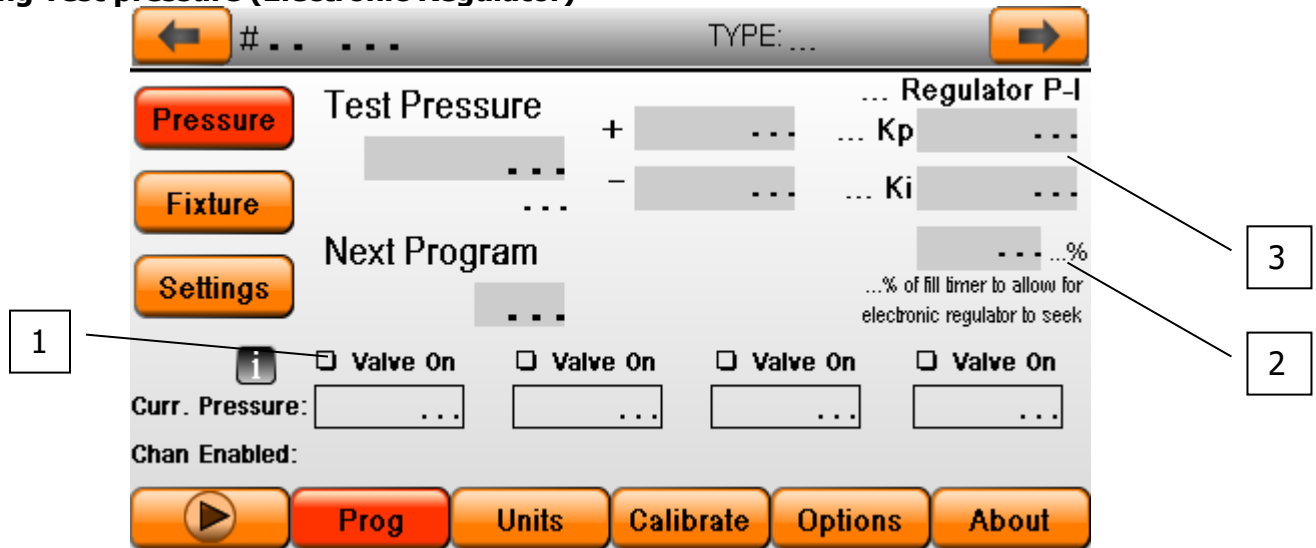

To set the test pressure, place a master part or plug onto the test port. Set the desired pressure in the 'test pressure' value box as well as the plus+ and minus- tolerance.

A secondary feature of the electronic regulator is the feedback loop. The (3) Kp and Ki controls. These controls are similar to a PID tuning algorithm. The Kp is the amount of drive for the regulator. The Ki is the amount of correction the regulator will receive as it gets closer to the target set point. The Kp and Ki controls allow the fill curve to be customized to fit the application parameters.

At the beginning of the fill step, the firmware will use the value from the calibration as the initial pressure output. If fine tuning is needed there are two options to choose from.

The percentage change (2) is the amount of time to fine-tune the test pressure. This value can be 1-99 (for example a 50% regulator seek time will adjust the regulator output in the last 50% of the fill timer). This mode will use the calibration value as the initial point and start the fine-tuning at the specified percentage. Setting the amount of feedback too high will cause oscillation. This value should be set to be enabled after the part has initially come to test pressure.

Setting the mode to 100% will use the Kp and Ki from zero pressure and adjust all the way to the setpoint using these constants.

Setting the % value to '0' will disable any feedback. To use the '0' mode the 'Valve on' will need to be checked with a capped test port to set the pressure value prior to testing.

Setting Test pressure (Manual Regulator)

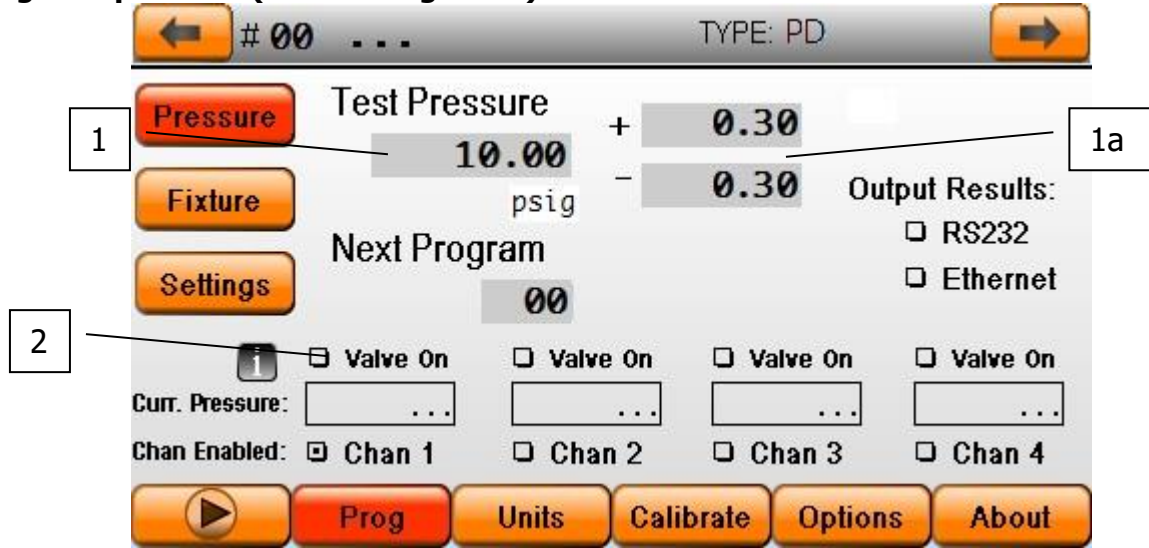

To set the test pressure, place a master part or plug onto the test port. (1) Set the desired pressure in the test pressure value box as well as the plus+ and minus- tolerance(1a), then check the "Valve On" box (2). The internal pneumatics will open to allow the pressure from the regulator out to the front port. The pressure sensor will show the current pressure in the space below the 'valve on' check box. Adjust the regulator until the specified pressure from the 'Test Pressure' value field is achieved. Uncheck the box when finished.

If timers have been set in the Fixture screen prior to the valve on checkbox, the clamp timers will operate when the valve on box is checked prior to opening the internal pneumatics.



Statistics are accessed via the Stats button on the Pressure screen

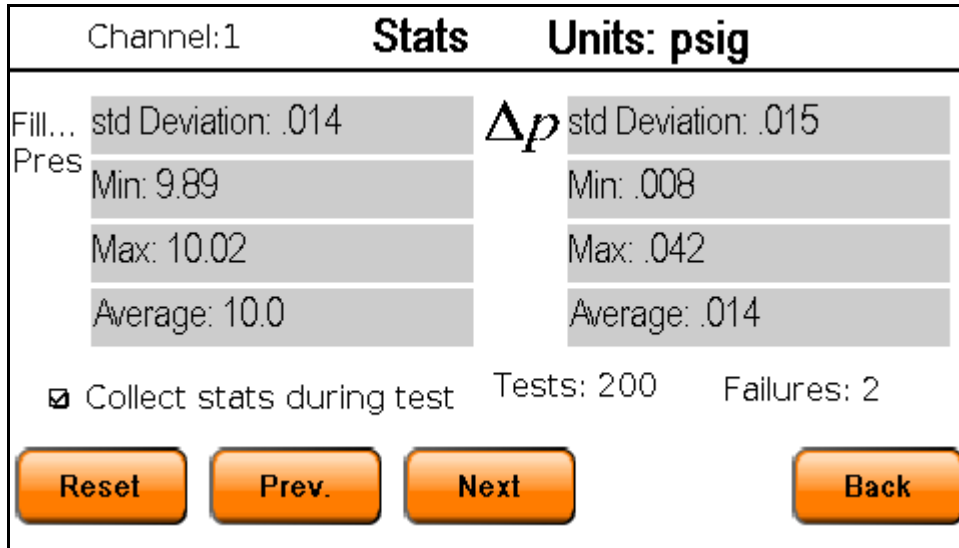

To enable the collection of data on the Fill pressure and Test decay check the box in the lower left corner. This will need to be done in all programs requiring the data. Multi-channel units will have an additional selection to step between channels.

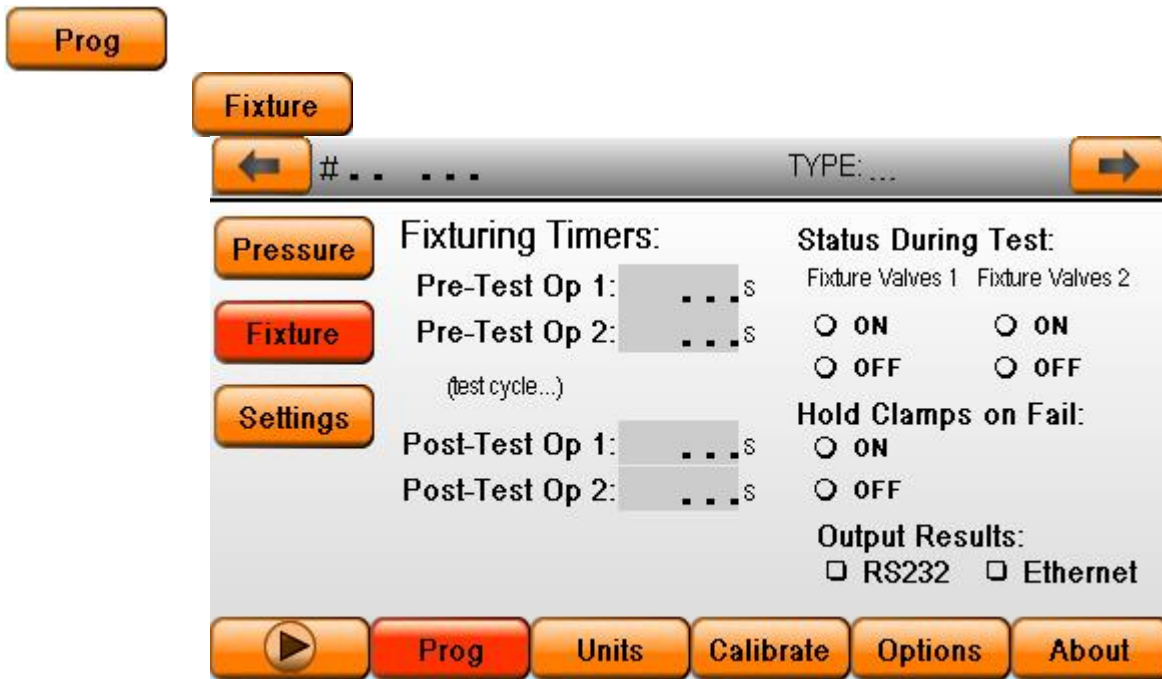

Clamps, Coupling outputs, and Fixturing Timers are all similar terms used to describe pneumatic outputs that can be used for various functions. These outputs can be used to actuate tooling, manipulate a part, or activate a pneumatic seal around a part. **All outputs are supplied as four-way valves with one normally open and one normally closed port. The outputs can be used as a three-way valve by plugging the normally open port. The normally open port will be plugged from the factory.**

The valve timers work in an On-delay, Off-delay manner. The output is set at the beginning of the timer. At the end of the cycle the outputs will deenergize in the opposite order.

Pre-Test Op1 is **output 1**. To enable the output, a minimum of 0.1 sec. must be entered. This timer is the amount of time the output will be set prior to the test start.

Pre-Test Op2 is **output 2**. To enable the output, a minimum of 0.1 sec. must be entered. This timer is the amount of time the output will be set prior to the test start. If op1 is set, op2 will follow and run its timer before the start of the test.

Leaving the post-test timers at zero will de-energize all valves at the end of the test. Placing time in the **'post test'** will de-energize the valve in the opposite of the order they were initiated.

Timing diagram below:

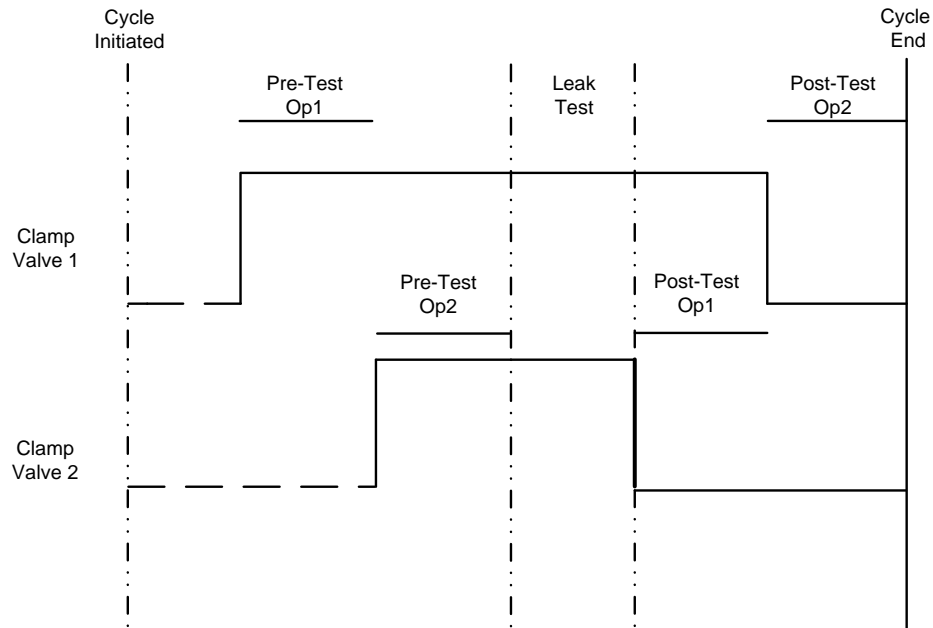

Status During Test: This is the state of the clamp valves during the 'Test' setup. Selecting the fixture valves to be off during test will turn off the output during the 'TEST' step. The default action is 'ON'

The typical use is on an occlusion (blockage) test type where the clamp valve will be used to release the part to allow pressure drop to occur to meet test limits. (Test details)

Hold clamps on Fail: When this option is selected the clamps will remain in their test position, the fail indicator LED will flash to alert the operator of the failure. The operator will acknowledge the failure by pressing the fail LED and the clamps will then follow the set release timer.

Note: The Pass/Fail results sent out the I/O will not be posted until the failure has been acknowledged.

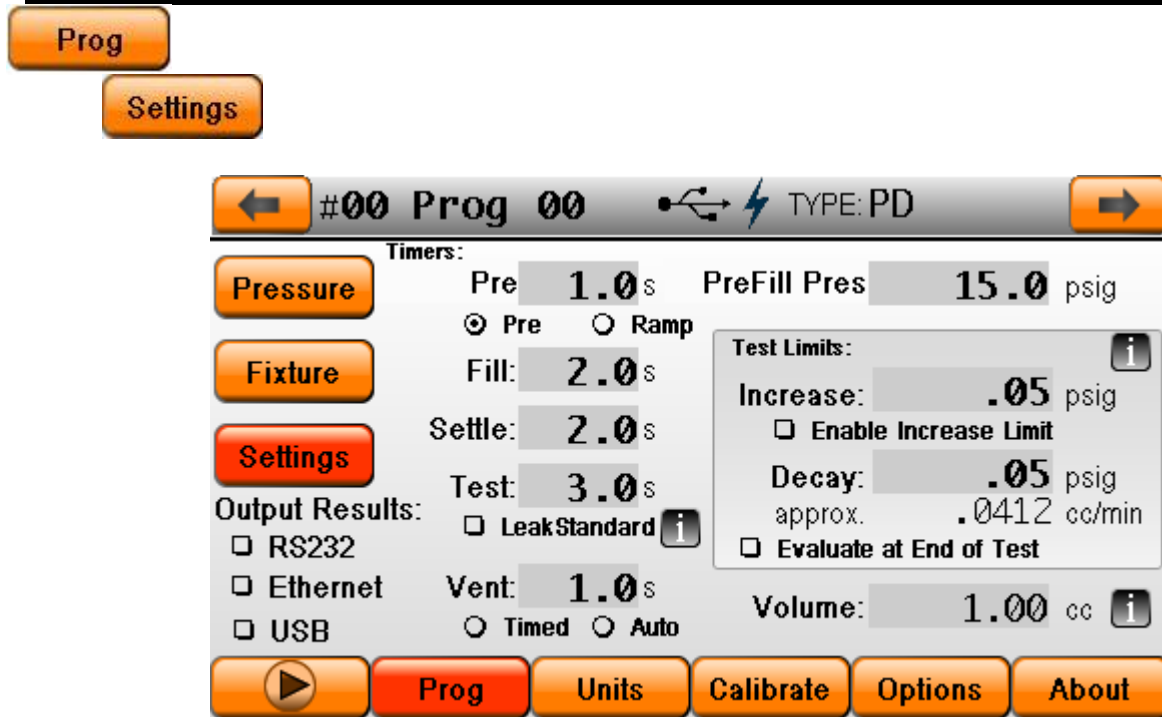

The timers shown in the settings menu will vary according to the test type. Refer to the test type setup section for details on each specific test type. This example is for Pressure Decay or Vacuum Decay.

Pre (Fill): (Option) Pre-fill allows the device under test to be filled via a second regulated source, typically at a higher pressure for increased air volume. This timer can be used in two ways. If 'Pre' is selected the pneumatic output will open for set amount of time. If the unit has electronic regulator and 'Ramp' is selected, the pressure will be ramped at the PreFill Pres rate per second. As shown above the ramp rate would be 15psi/sec.

Note: If Pre-Fill is not purchased and installed, set the timer and Pre-fill Press to '0'

Fill: The amount of time the to fill the test part with regulated pressure.

Settle: The amount of time after fill valves have closed isolating the test part from any incoming pressure.

Test: This timer is the amount of time set to observe for decay in pressure. The decay in this step will be evaluated against the test limits to determine Pass/Fail of the test.

Leak Standard: (Option) Units equipped with the secondary leak standard port can select this box in order to include the standard during the test (self-test).

Vent: The 'Vent' timer is used to relieve pressure on the part prior to the operator removing it from the tester. Selecting 'Timed' will vent the pressure for the specified amount of time. Selecting 'Auto' will release the pressure to a safe limit (0.5psi typical). Once the pressure is released, the test is concluded.

Test Limits Continued...

Prog

Settings

Pressure/Vacuum Decay Limits:

A not-to-exceed amount of decay before the timer expires for a pass condition. If the Decay limit is reached before the timer, the test will short cycle and result in a failed condition. To see the decay in the full timer length, check the Evaluate at End of Test box.

An increase limit can be set to verify that no external or thermal dynamic forces cause the pressure to increase over the test time. This limit must be enabled by checking the box. If the increase limit is used, the Evaluate at End of Test box must also be checked.

Test Limits: ⓘ

Increase: []

Enable Increase Limit

Decay: []

approx. . . . cc/min

Evaluate at End of Test

Occlusion Test Limits:

A set amount of decay must be reached by the end of the time for a pass condition. Any decay greater than the limit before the timer expires will short cycle the test with a pass condition.

To run the test step to the end of the timer regardless of the value check the Evaluate at End of Test box.

Test Limits: ⓘ

Decay: []

approx. . . . cc/min

Evaluate at End of Test

Flow Test Limits:

A minimum and maximum flow boundary is set for a pass condition. Pass/Fail condition is evaluated at the end of the Flow step.

Test Limits:

Max Flow: [] . . . sccm

Min Flow: [] . . . sccm

Burst/Crack Test Limits:

A minimum and maximum pressure boundary is set for a pass condition. The burst trigger is the amount of pressure drop expected when the burst even occurs.

The test will short cycle when the trigger occurs. The Pass/Fail status will also be evaluated at the trigger point.

Test Limits:

Max Burst: []

Min Burst: []

Burst Trig: []

Volume: Entering the total test volume (part, tooling and tester) enables a calculated volumetric leak rate to be shown in the result box in the run mode. This calculation should only be used as a reference. For a true decay based on a volumetric leak rate, Zaxis manufactures transfer standards to your leak rate specifications. This 'leak standard' is NIST traceable and can be used for a daily verification of you test process.

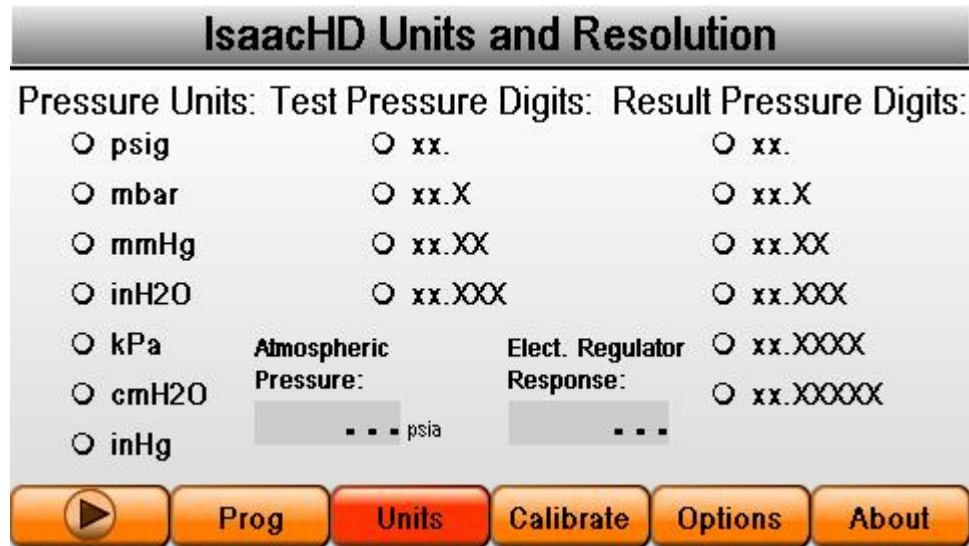

There are six selectable engineering units on the setup screen.

These units are:

- **psig** – pounds per square inch gauge.
- **mbar** – millibars.
- **mmHg** – millimeters of mercury.
- **inH2O** – inches of water column.
- **kPa** - kilopascals.
- **cmH2O** – centimeters of water
- **inHg** – inches of mercury

The atmospheric pressure used in the 'sccm' leak rate calculation of a pressure decay test. The default value is set to the pressure at sea level 14.70psia.

Test Pressure and Result Pressure resolution can be modified by selecting the appropriate radio buttons.

Calibration

Introduction to Calibration

In technical language, **calibration** is referred to the process used to determine accuracy. It is the comparison of a measuring instrument against a standard to establish the possible errors in a specific range.

Calibration is of such importance that the United States Government created an agency called the National Institute of Standards and Technology (NIST) that is tasked to maintain standards for values of SI units and industrial standards, calibration has become a helpful tool in providing the traceability of their subjects of study by adhering to the basic standards of calibration. **All Zaxis calibrations are traceable to standards set by the NIST.**

The Isaac can use up to ten calibration points throughout the range of the sensor to correct the linearity of the sensor output. All ten points are dynamic, meaning they can be adjusted to match where the user needs the best accuracy across the range.

In the calibration mode the pneumatic assembly will open to bring pressure, vacuum, or flow to the test port. The sensors will also be active to show the current reading. With a pressure or flow standard attached to the test port the machine is taught the values from the standard. Calibration points have been selected across the range at the factory the greatest accuracy.

Two procedures will be outlined, Calibration Verification and Calibration Modification. All Isaac models are initially calibrated at our facility. The verification procedure should be the most used. If the calibration needs to be modified, then use the modification procedure.

Calibration is always to be performed in units of psig.

Important: Calibration of this instrument is for the sensor only (not a leak calibration) and is factory set. Leak standards can be obtained from Zaxis Inc. and can be used as a transfer standard to establish applicable leak rates. All standards should have at least three tiers of uncertainty. i.e. Isaac has a tolerance of .25% FS (full scale) therefore pressure standards should be at least equal to or less than .1% FS.

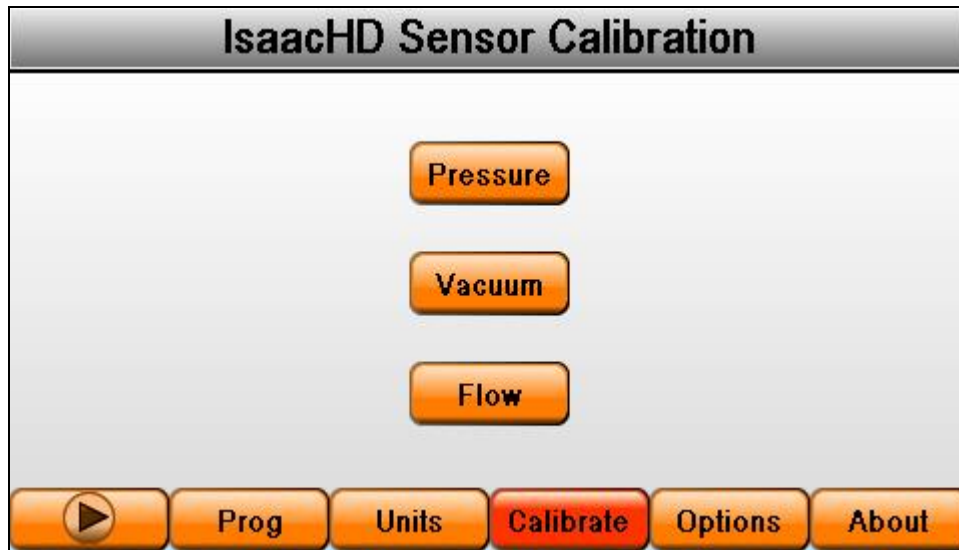

Selecting the calibrate button will open the sensor selection screen. A warning box will appear. To continue into the calibration screens press '**Calibrate**'.

Three sensor types are shown Pressure, Vacuum, and Flow. Even though all three sensor types are shown each unit will have model specific sensors installed. For details see the calibration report shipped with the tester.

Isaac with pressure standard



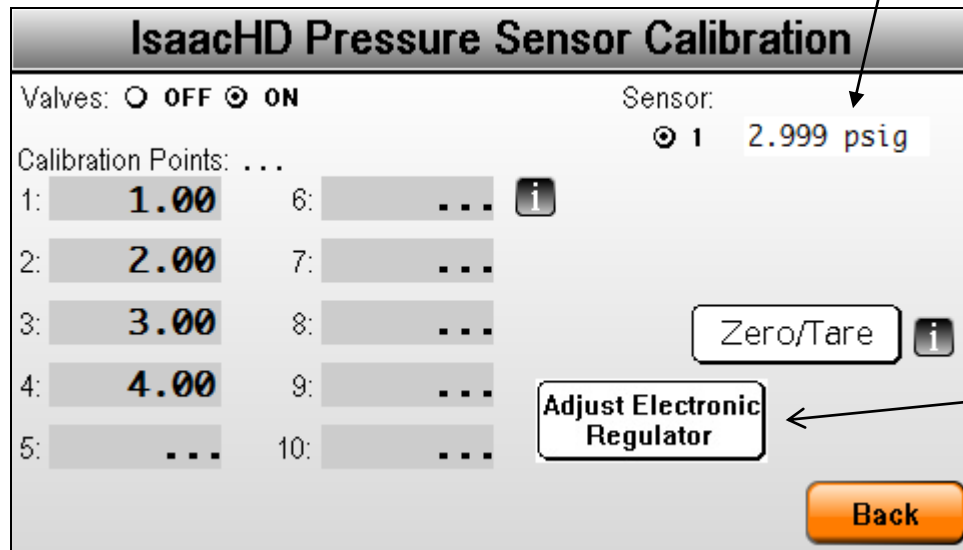

The following procedure is done with a manual regulator. * For machines with the optional Electronic Regulator see the [adjustment control section](#) for fine-tuning details.

1. Enter calibration screen and connect the test port of the Isaac to a pressure standard.
2. Select the sensor number to be calibrated in the upper right corner. (Concurrent models have multiple sensors to calibrate)
3. To apply regulated air to the sensor, press the **Valves**: "ON" button.
4. Adjust the regulator to the desired pressure reading on the **pressure standard** and compare the reading of the sensor. (Upper right corner)
5. Repeat step 5 for all required calibration points.

To change or fine tune a set point, do the following.

1. Adjust the regulator to the desired calibration point on the **pressure standard**.
2. Press the value field of the calibration point to be modified. A numeric keypad will appear, enter the value to be set, or press enter if the value is correct.
3. The current reading of the sensor will adjust to the corrections and display the new value.

The TARE button serves as the zero pressure/flow set point. When setting this point no pressure or flow should be present on the machine.

To exit and save the calibration, press the  button.

! Caution: If a calibration point data field is pressed unintentionally, the only way to keep from changing calibration is to immediately shut-off power to the unit.

Calibration points should be incremental, with point 1 being the lowest value. Values do not need to be whole numbers.

Special Note: Sequential models can trap a small amount of pressure internally between the channel selection valve and the pressure transducer. Make sure to open the valves to clear any pressure before pressing the TARE button.

Flow Calibration –

There are two typical flow standard systems to use in calibration of Isaac flow sensors. The first is an orifice that with differing applied pressures produces multiple flow rates. The second is a high accuracy flow element with an analog output or display. Because both are calibrated and traceable either can be used to calibrate and Isaac.



This image is a typical flow calibration setup with a digital mass flow standard. The Isaac provides a constant pressure and the needle valve varies the flow to make the calibration point.

Electronic Regulator (Optional Item)

With the optional electronic regulator installed adjusting pressure values is done through the software via buttons on the touch screen. The calibration procedure will follow as listed in this manual; the only difference is how the regulator is adjusted to achieve the set points.

Adjust Electronic Regulator

In the calibration screen an additional button is available: This button will open the regulator control screen.

Six buttons will be used for increasing or decreasing the output pressure of the regulator.

+ Small Increase, ++Medium Increase, +++ Large Increase

- Small Decrease, -- Medium Decrease, ---Large Decrease

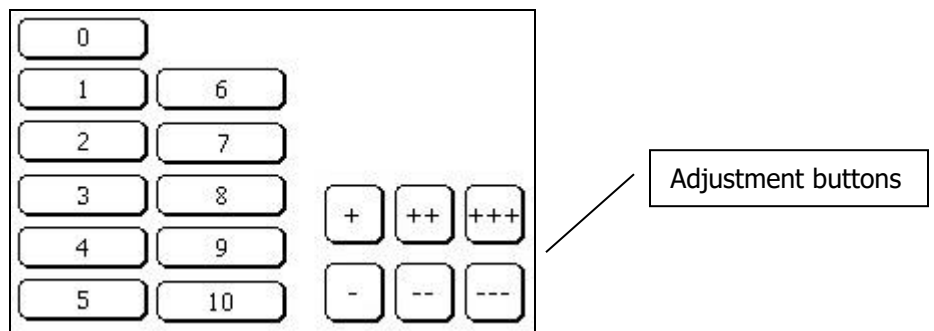

The buttons on the left side (0 through 10) are the previous settings of the regulator for each numbered calibration point; these buttons can be used to 'jump' to the previously set pressure before beginning the fine-tuning process.

A live pressure reading is shown in the upper right corner.

Once the desired pressure is maintained pressing the 'Back' button will return to the calibration screen where Cal Points can be set.

NOTE: To decrease the effects of hysteresis, perform the adjustments of the electronic regulator in the upward direction, that is, approach the target from a lower value without going over.

After the calibration has been performed, press the BACK button to exit to the run screen.

Options Menu

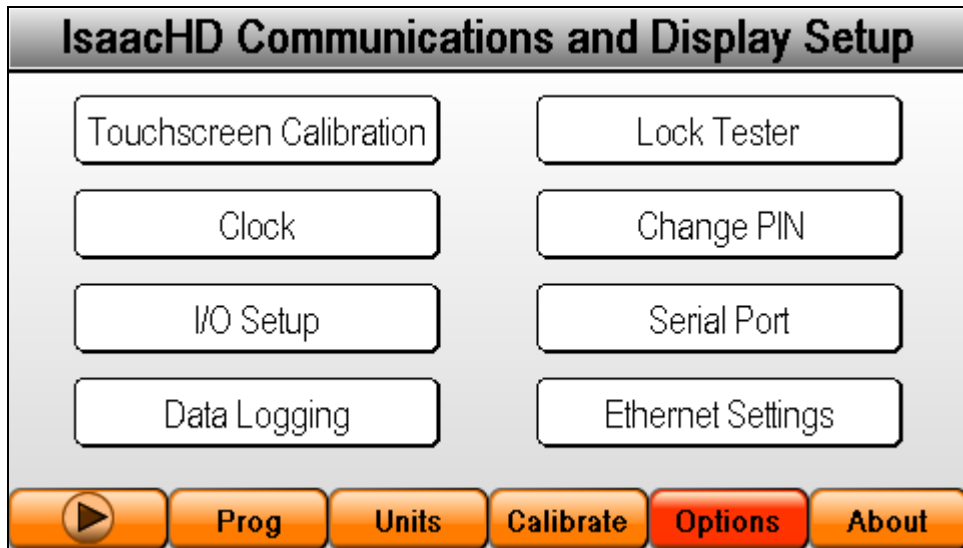

The option screen has eight menu buttons:

- 1) Touchscreen Calibration
- 2) Clock
- 3) I/O Setup
- 4) Data Logging
- 5) Lock tester
- 6) Change PIN
- 7) Serial Port
- 8) Ethernet Settings



Touchscreen Calibration

The touch screen has been factory set. Typical use of the Isaac will not require this function to be used.

Entering the calibration screen the user will be asked to touch specific targets to adjust the touch pad to the display.

Options

Clock

Clock

Date:
(mm/dd/yy)

Time:
(hh:mm:ss)

Modified values will not be displayed until power is cycled off/on. Change one field at a time – cycle power after changing each field.

[Back](#)

To modify either the time or date, touch the field to be changed. A keypad will pop-up to make the desired changes. Cycle power after changing each field.

Options

I/O Setup

I/O Setup

Binary Program Selection Bits:	Program Start Mode:
<input type="radio"/> 0 (Program select off)	<input type="radio"/> Start on Input 1
<input type="radio"/> 1 (Programs 0 - 1)	<input type="radio"/> Start on Input 1 & 2 (Anti-Tie)
<input type="radio"/> 2 (Programs 0 - 3)	<input type="radio"/> Start on Input 1 & Start Button
<input type="radio"/> 3 (Programs 0 - 7)	
<input type="radio"/> 4 (Programs 0 - 15)	
<input type="radio"/> 5 (Programs 0 - 31)	
<input type="radio"/> 6 (Programs 0 - 63)	
<input type="radio"/> 7 (Programs 0 - 99)	



Binary Programmable Selection Bits

Each stored program can be selected by a digital bit pattern. Select the number of programs to be used by the I/O. This action will disable the program number select on the front display and will always return to the program selected by the active inputs. For example if a selector switch is wired for fifteen tests (BCD 1, 2, 3, and 4) select bit 4. If there are no active bits the test displayed will be Program 0.

Program Start Mode

There are three options of test start.

Start on Input 1: Activating input 1 on the I/O connection will start the cycle. The input starts the test on the rising edge of the signal. This selection is the default, and allows the start button to run initiate the test. (Input 1)

Start on Input 1&2 (Anti-tie): This option is used when an operator needs to be clear of movement in the fixture. Two separate switches must be contacted within 300msec of each other, one switch cannot be held closed while the other is triggered. (Inputs 1 and 2)

Start on Input 1 & Start Button: This option has a condition to be met before the test can proceed. Input 1 on the I/O connector must be held active before the START button is pressed. If the input is released before the test ends, the test will abort. A typical application would be for a door switch on a safety enclosure. (Input 1)

Options

I/O Setup

I/O Test

This screen allows the user to test the input bit pattern to help debug wiring from the remote control (PLC etc.). The value from the input register will display when the input is held active. (See I/O pin out chart for Input Test Values)

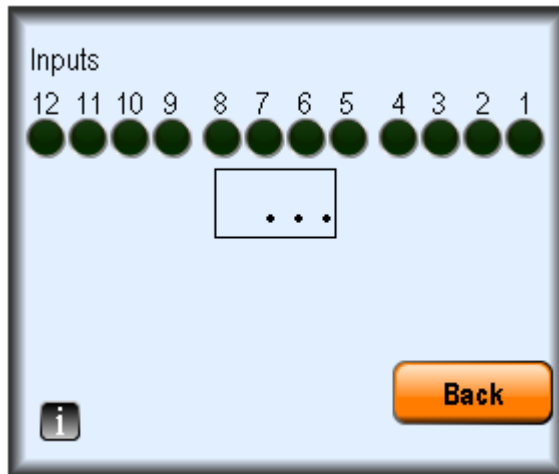

In this screen when an input is active its corresponding output will also be active. For example when input 5 is set active, then output 5 will be active.

Input / Output Connector Pin-out

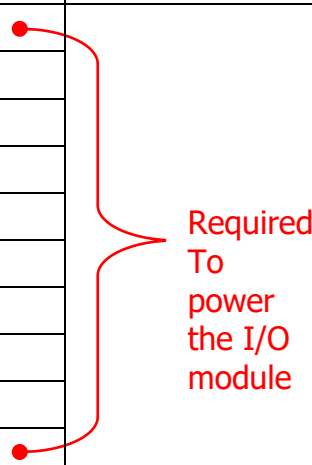
Item	Description	PIN	Input Test Value
IN 1	START	26	1
IN 2	START (ANTI-TIE ENABLED)	27	2
IN 3	BCD 1 (LSB)	28	4
IN 4	BCD 2	21	8
IN 5	BCD 3	22	10
IN 6	BCD 4	23	20
IN 7	BCD 5	24	40
IN 8	BCD 6	25	80
IN 9	BCD 7 (MSB)	16	100
IN 10	NOT USED	17	200
IN 11	NOT USED	18	400
IN 12	ABORT	19	800
+24VDC	User to Supply +24VDC	20	 <p>Required To power the I/O module</p>
OUT 1	BUSY	1	
OUT 2	GLOBAL PASS	2	
OUT 3	GLOBAL FAIL	3	
OUT 4	CH 1 FAIL	4	
OUT 5	CH 2 FAIL	5	
OUT 6	CH 3 FAIL	6	
OUT 7	CH 4 FAIL	7	
OUT 8	CH 1 PASS	8	
GND	User to supply GND	9	
OUT 9	CH 2 PASS	10	
OUT 10	CH 3 PASS	11	
OUT 11	CH 4 PASS	12	
OUT 12	NOT USED	13	
+24VDC	Common to Pin 20	14	
GND	Common to Pin 9	15	

I/O Circuit

Input Circuit Diagram

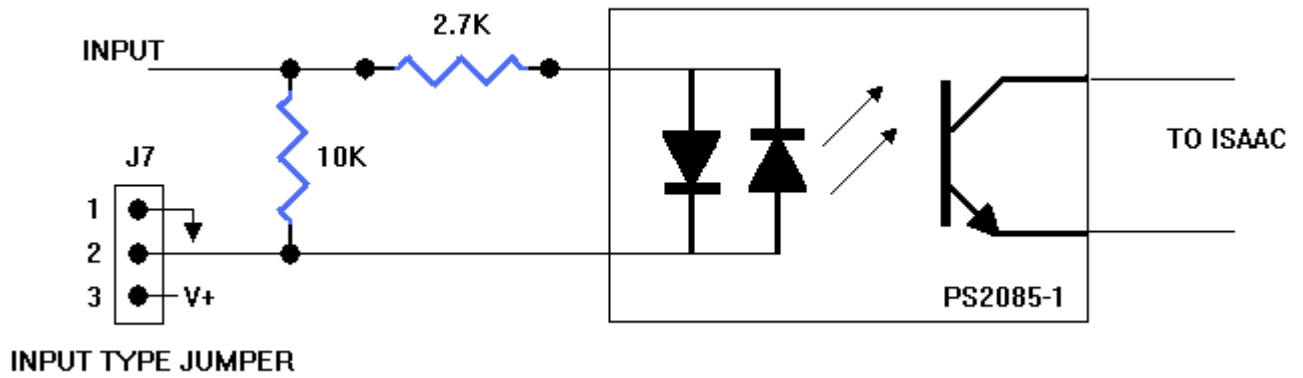

Output Circuit Diagram

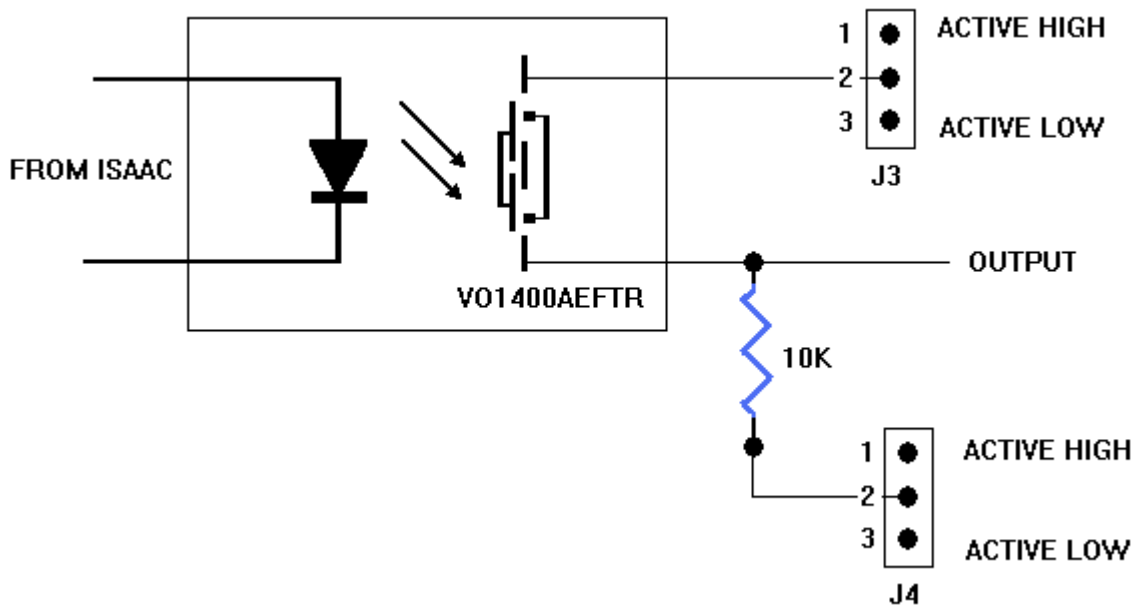

I/O Hardware

The I/O module on the HD has two different models (sourcing or sinking). The selection must be specified at time of manufacture. The active status can be identified by the color of the module. Active high modules are green. Active low modules are purple.

For operation there is a required supply voltage for the module, this is typically the same supply as the PLC or I/O card controlling the unit.

The active high module (sourcing) requires +24VDC to activate an input. +24VDC will be returned on the pin of the active output.

The active low module (sinking) requires GND (common) to activate an input. GND will be returned on the pin of the active output.

The active status can be identified by the color of the module. Active high modules are green. Active low modules are purple.

The current required to activate an input is 50mA.

The max current that can be supplied from and output is 350mA.

The I/O was designed for low amperage connection to a PLC. If outputs are wired directly to mechanical relays, a diode should be placed across the connections as show below. This fly-back diode will protect the I/O from damage caused by a large voltage increase as the coil de-energizes.

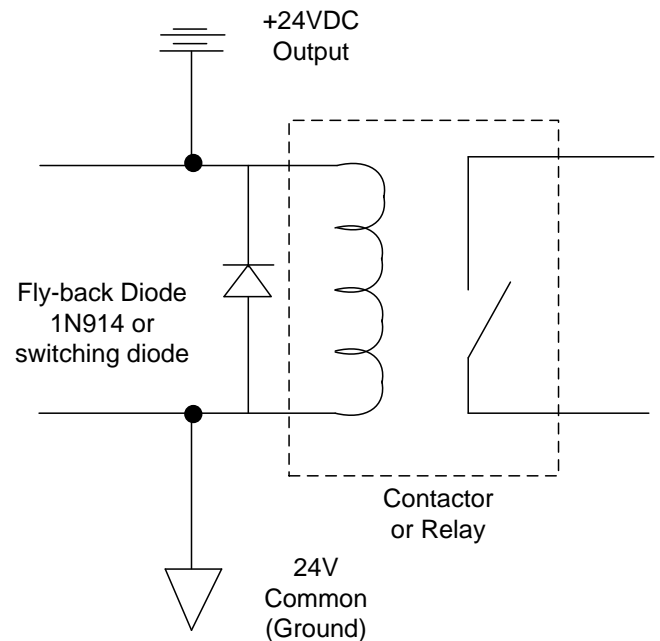

I/O Timing Chart

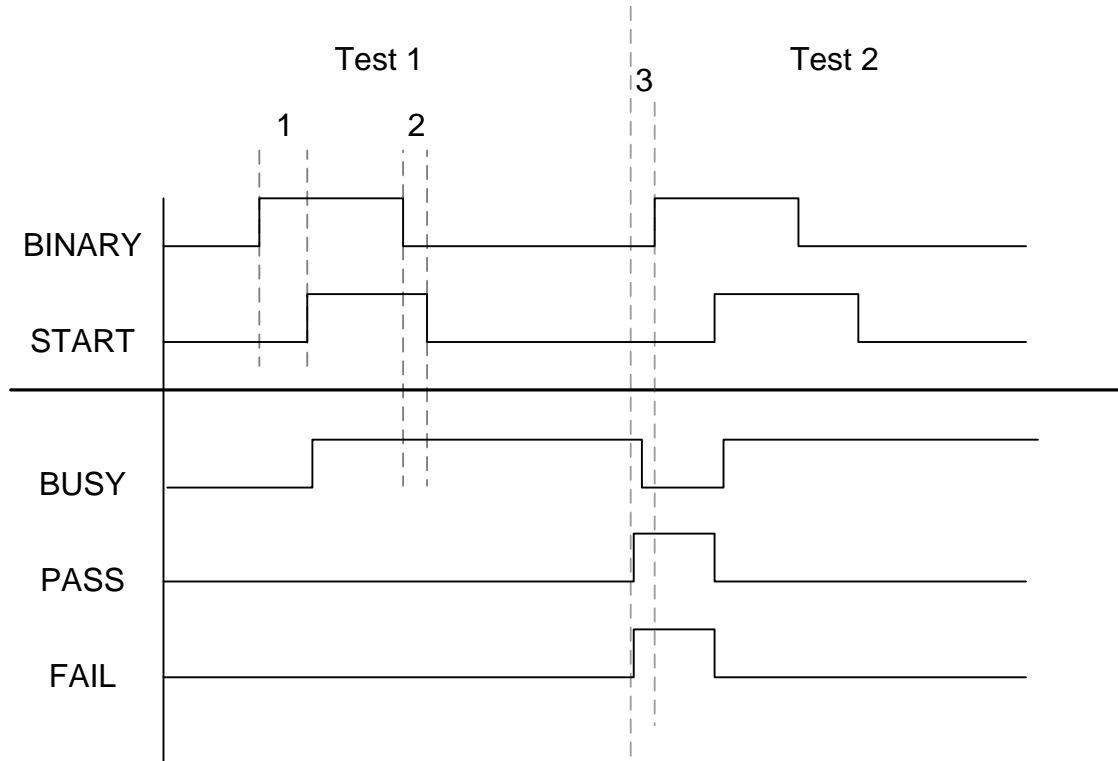

- 1 – Binary should be active 100ms (min) before the Start signal
- 2 – Binary and Start signals should be released after Busy is verified

Options

Data Logging

Data Logging

Data Logging Output:

- Disable data logging
- Log result only
- data out every 0.1 sec
- data out every 1 sec

Back

Test result fields are TAB delimited.

Log Result Only

(Header for descriptive purpose, not printed in data string)

Date	Time	Program #	Program Name	Test Type	Result	Value
01/26/09	11:10:34	01	PROG 0	Flow	Low Flow	0.01
01/26/09	11:10:42	01	PROG 0	Flow	Pass	100.21
01/26/09	11:10:50	01	PROG 0	Flow	Pass	99.13

0.1s Data

(Header for descriptive purpose, not printed in data string)

Step	Time	S	Reading				
Fill	0.5	s	22.65				
Fill	0.4	s	99.56				
Fill	0.3	s	99.55				
Fill	0.2	s	99.43				
Fill	0.1	s	99.43				
Fill	0.0	s	99.25				
Test	0.9	s	99.24				
Test	0.8	s	99.22				
Test	0.7	s	99.20				
Test	0.6	s	99.15				
Test	0.5	s	99.13				
Test	0.4	s	99.13				
Test	0.3	s	99.13				
Test	0.2	s	99.13				
Test	0.1	s	99.13				
Test	0.0	s	99.13				
01/26/09	11:10:50	01		PROG 0	Flow2	Pass	99.13

1s Graph

The output similar to 0.1s Graph, sampling time changes to 1 second.

Settings

Lock Tester

Lock Tester

Program Parameter Editing:	<input type="radio"/> Locked	<input type="radio"/> Unlocked
Current Program:	<input type="radio"/> Locked	<input type="radio"/> Unlocked
Calibration:	<input type="radio"/> Locked	<input type="radio"/> Unlocked

[Back](#)

Three sections of the tester can be locked (not able to be edited). Select the section to lock by touching its radio button.

Locking the calibration will not allow access into the menu screens entirely.

Settings

Change PIN

Current PIN:

New PIN:

Re-enter New PIN:

To lock the tester a PIN number (4 digits) must be established. The Current PIN: from the factory is blank.



Settings

Serial Port

Serial Port Setup

Baud Rate:

- 9600
- 19200
- 57600
- 115200

This feature allows data logging via the serial port. The data bits, parity, stop bits, and flow control are hard coded in the Isaac.

- Data bits - 8
- Parity - None
- Stop bits - 1
- Flow Control – None

The baud rate is selectable and has four selections, **9600**, **19200**, **57600**, and **115200**

To receive data from the serial port, the RS232 selection must be enabled for each test you wish to collect.

Output Results:

- RS232
- Ethernet

Serial Port (RS232) Wiring

The RS232 serial port on the rear of the test is a valuable tool to collect test results. The serial connection is a simple 'three wire cable'.

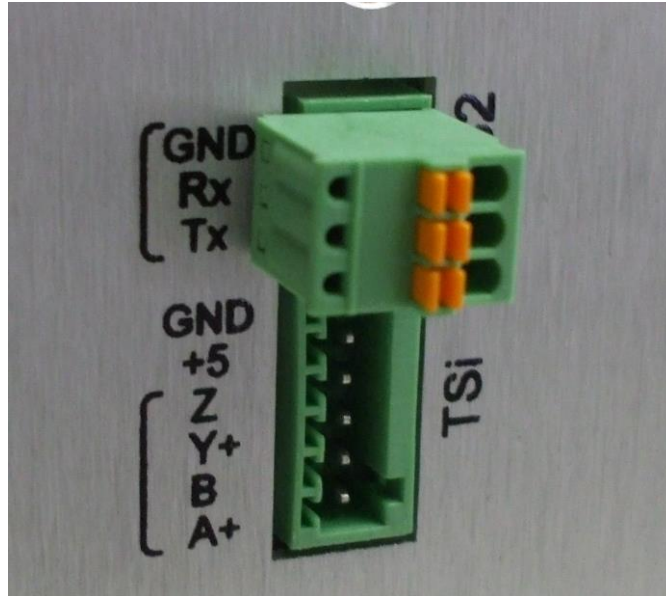

The RS232 serial port on the rear of the test is a valuable tool to collect test results. The serial connection is a simple 'three wire cable'.

The RS232 connections are screen printed on the rear of the tester.

GND = Ground
Rx = Receive
Tx = Transmit

The mating connector is removable and is held in place by a friction fit. The orange buttons are a spring catch release that will hold the connection wires. To insert a wire depress the orange button while inserting the stripped wire until it meets the bottom of the connector. The wires should be stripped back with 8mm bare wire.

The wiring of the complete cable is as follows:

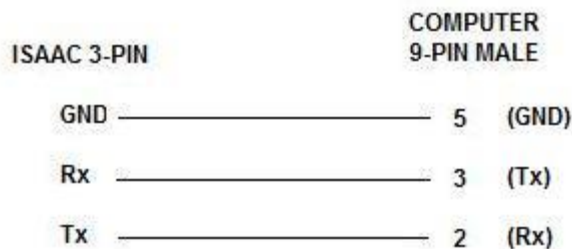

Settings

Ethernet Settings

TCP/IP Settings

IP Address: . . .

Netmask: . . .

Gateway: . . .

DHCP: . . .

MAC Address: . . .

Back

ASCII data over the Ethernet

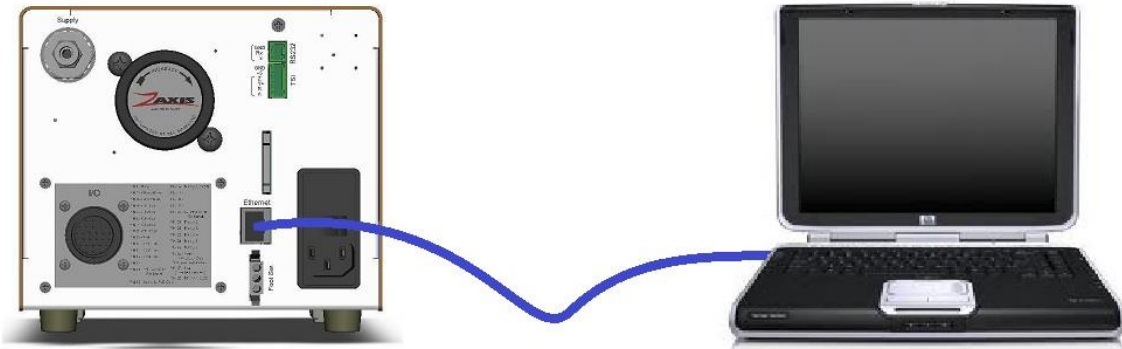

The test data from an Isaac can be collected by a computer via the Ethernet connection on the back of the Isaac.

To collect data on a laptop you will need a crossover Ethernet cable ([see diagram](#)) and a terminal emulation program such as HyperTerminal.

NOTE: If your primary network connection is done wirelessly, you will need to connect the cable from the Isaac to your laptop, and cycle the power on the Isaac. To verify that the Ethernet socket is active, a green light will be visible inside the machine, towards the bottom of the Ethernet jack.

To begin find the IP address of the laptop by running the 'command prompt' found in Start – Accessories or type 'command' in the search bar of the start menu.

On the command line type 'ipconfig', this will display all the data associated with the Ethernet connections. Scroll down to the section 'Ethernet adapter Local Area Connection' record the value of the 'IPv4-Address'.

On the Isaac, under 'OPTIONS' – 'Ethernet Settings' turn the DHCP selection to **OFF**. The *IP Address* of the Isaac should be set to one address higher than the IP of the laptop.

For example Laptop = 169.254.96.1, set the Isaac to 169.254.96.2

Verify that the correct selections have been made in the 'Data Logging' menu for the type of data you wish to collect (Results, 0.1sec data, etc.) Also verify that 'Output results' in the 'PROG' menu have the Ethernet box selected for every test you wish to collect.

Starting HyperTerminal, the opening screen asks for a connection description, this description can be saved for future use to avoid going through all the configurations. We have chosen to call our example 'Isaac'.



With a connection description made the next screen to appear is Connect To. Hyper terminal has multiple ways of communicating. In the Connect using pull down menu choose TCP/IP (Winsock).



With the TCP/IP selection made the Host address and port numbering must be entered. The IP of the Isaac is the Host. The port number is always 23.



Pressing OK will initiate the socket connection from HyperTerminal to the Isaac. A successful connection will be shown by the connected counter in the lower right corner of the HyperTerminal screen.



The easiest way to verify communication is to start and abort a test. The data string will display after the abort. A typical string is shown below.

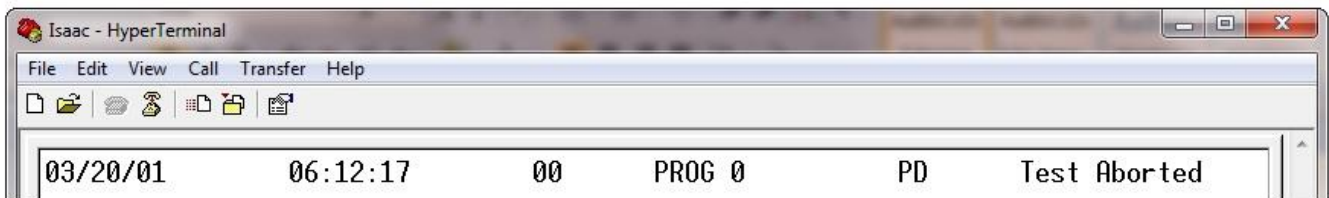

To gather multiple tests automatically, HyperTerminal has a feature to collect the text and save it to a file. Select 'Transfer' then 'Capture Text...'

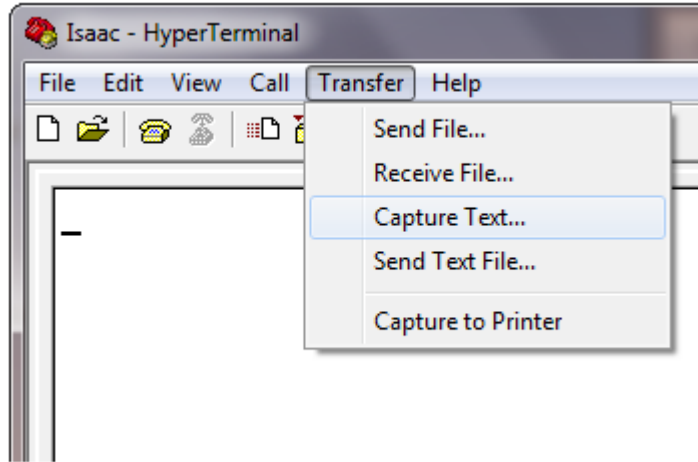

HyperTerminal will now ask for a filename for the data. Remember to make sure the extension is .TXT

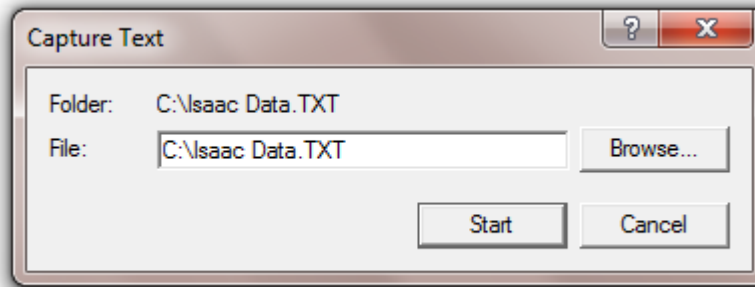

With a file name chosen, press start to begin the collection. Any data sent from the Isaac will be recorded under the filename that was specified, until you return to the 'Transfer' and 'Capture Text..' and press stop.

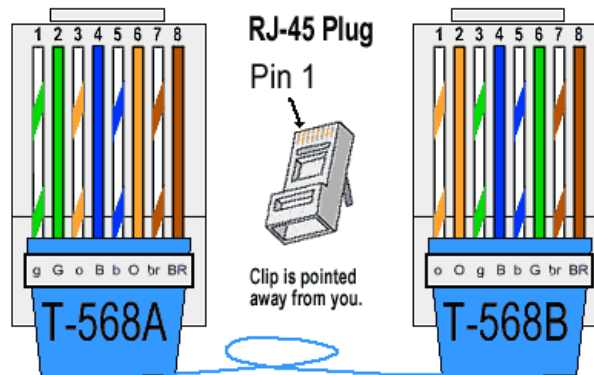

2442 South 2570 West
West Valley City, UT 84119
Phone: 801-264-1000
www.zaxisinc.com

Test Type Setup

The Isaac series of leak testers are multi-parameter instruments. Each unit can have multiple testing techniques installed.

Some of the available testing techniques are:

- Mass Flow – Flow (Measures flow of a device ant a given backpressure)
- Backpressure Flow – Flow (Measures the backpressure created from a given flow through a device)
- Occlusion – POccl (Measures a pressure drop to find a blockage using positive pressure)
- Occlusion – VOccl (Measures a pressure drop to find a blockage using negative pressure)
- Vacuum Decay – (Measures decay of vacuum pressure)
- Burst – (Ramps test pressure into the device to find opening or bursting pressure)
- Crack – (Ramps test pressure into the device to find opening using a downstream sensor for the ‘event’)
- Creep – (A series of pressure ramping pressure decay test.)
- Pressure Increase – (Pressurize one side of a part and watch the opposing side for an increase of pressure due to a leak across the common wall.)
- Chamber Test – (Pressure decay or Vacuum decay testing of sealed volumes (e.g. packaging))
- Pressure/Vacuum Exercise - PExer/Vexer
- Re-seat – Valve (used with a crack or burst to determine device closing pressure)

The following sections will describe the setups for these test types.

PD (Pressure Decay)

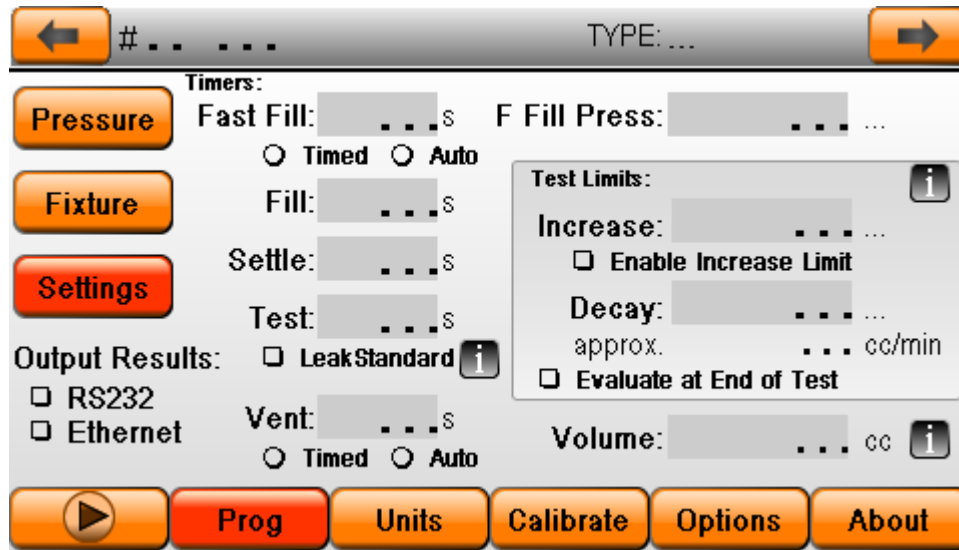

There are four timers for a typical pressure decay test. Optional timers would include Clamping and Fast Fill.

Pre-Fill – This timer requires optional pneumatic components to operate and works in conjunction with the **Pre-Fill Pressure** field. Fast fill is a primary fill step used to quickly fill large volumes by using a secondary regulator set at a higher pressure to increase the volume of air being introduced into the part. This step will terminate at the completion of the timer or when the entered pressure is reached (Radio button selection). A step with a time of zero will be skipped.

Fill – the Fill timer is the amount of time allowed to reach the test pressure, and is subject to the pressure tolerance. If the pressure increases above the plus tolerance a HI PRESSURE error will occur and will end the test. If the fill time elapses without the pressure reaching the test pressure minus tolerance a LO PRESSURE error will occur and end the test.

Settle - At this point the supply pressure has been isolated from the unit under test. During this timer the air and the part are allowed to settle. Parts that have a more flexible nature should be given more time to reach a steady state for testing. If the pressure drops below the test pressure minus tolerance a GROSS LEAK error will occur and end the test.

Test - During this step the decay of pressure is monitored. If the decay is equal to or greater than the reject level, the test will end and a reject indicator will illuminate (RED LIGHT) and an audible tone will alert the operator of the failure. If the pressure does not drop below the reject level and the time expires, the part is has passed and an accept indicator will illuminate. (GREEN LIGHT).

Vent - This is the amount of time to exhaust the pressure from the unit under test. Primarily this is used as a safety to remove pressure away from the operator. The pressure is vented internally to the Isaac. If the auto button is checked, the unit will automatically vent until test cavity pressure is less than 20 mbar. If the timed button is selected the vent will occur for the specified amount of time.

Options are available for the exhaust to be ported to the back of the Isaac for exit of a clean room. And vacuum assisted vent to collapse the device (bags) for storage and transport.

Test Limits - A not-to-exceed amount of decay before the timer expires for a pass condition. If the Decay limit is reached before the timer, the test will short cycle and result in a fail condition. To see the decay in the full timer length, check the Evaluate at End of Test box.

An increase limit can be set to verify that no external or thermal dynamic forces cause the pressure to increase over the test time. This limit must be enabled by checking the box. If the increase limit is used, the Evaluate at End of Test box must also be checked.

Volume – The Isaac can calculate the pressure drop of the test to show in a volumetric flow rate (sccm). By entering the total volume of the part, any connection or fixture volume, along with the internal volume of the tester, the flow rate will be calculated. The screen will show the approximate sccm value if the part were to reach the full decay. Both the pressure decay and the leak rate will be shown on the main run screen.

$$\text{Leak Rate (cc/m)} = \frac{\Delta P \text{ (psi)} \cdot \text{Volume (cc)}}{\Delta t \text{ (minutes)} \cdot \text{ATM (psia)}}$$

The atmospheric pressure used in the on-board calculation is in the  menu.

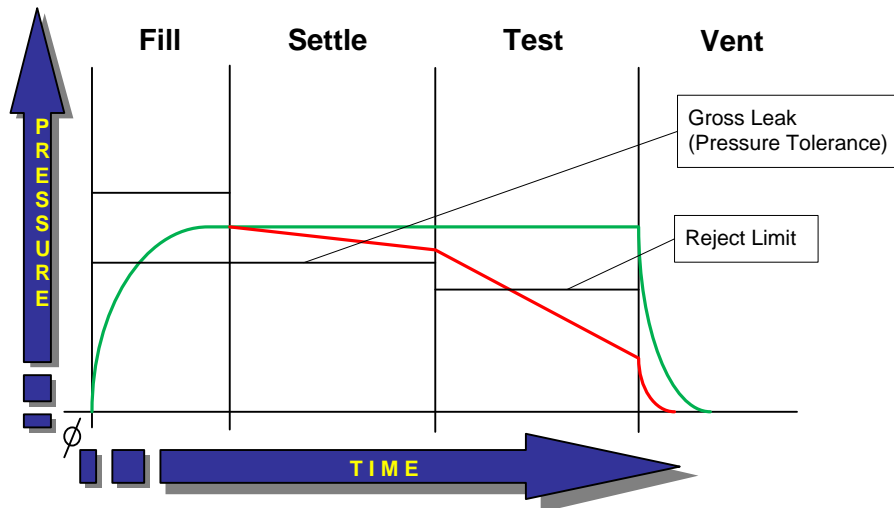

Mass Flow

The mass flow test is used to quantify air flow values through a part, inspect for occlusions blocking the flow path, and can also be used as a leak test.

The main program screen is identical to the setup of a pressure decay test. The coupling menu will behave as described earlier in the manual.

The flow parameter screen has all the needed timers and limits to run the test. The test can be performed with or without a fill step. The fill step uses a bypass circuit to achieve test pressure in the unit under test. The test can be setup without the fill step; this will subject the device to fill through the sensor which may fill at a lower rate.

The scale of the graph in the 'main' screen line-format is set by the min and max flow values. The top of the graph is the max flow value and the bottom of the graph is the min flow value. The horizontal scale is the total cycle time. A vertical line will represent the change between fill and test.

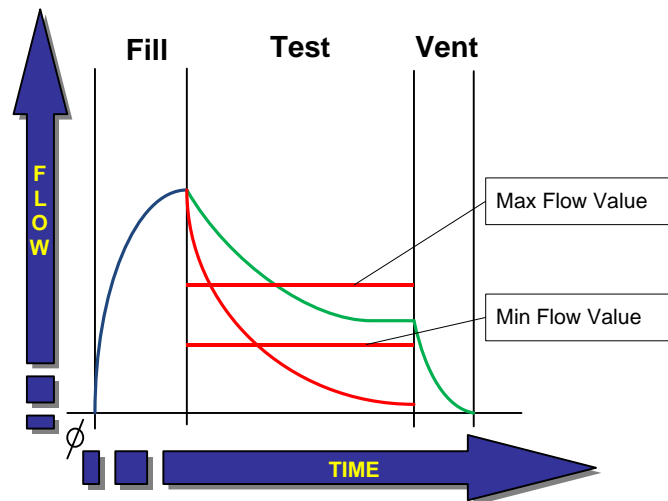

Burst

The burst test can be used in both destructive and non-destructive applications. A single test port and sensor will be used for all parts of the burst test. The device will be tested by a ramping pressure, at the point of rupture or opening, a small pressure drop is sensed by the internal transducer. This drop is the burst event; the peak pressure is recorded and compared to the limits to determine the pass/fail status. Burst triggers are typically very small values.

On manual regulator units, the ramping rate is physically set from a needle valve on the rear of the unit. With the addition of the electronic regulator option, the ramp rate is set as parameter setting. No test pressure is set on the PRESSURE screen as the amount of pressure is ramping.

The optional Pre-Fill step is included to allow for filling of large volumes before ramping begins.

The burst test is runs within a single 'test' step. The Min and Max pressure values create a window for the pass/fail status. If a part reaches the max limit an error of NO BURST HI will be displayed, conversely if the part bursts below the Min limit an error of LO BURST will be displayed. The 'trigger' or 'event' is the amount of pressure drop that occurs from the device rupture or opening.

Test Limits:	
Max Burst:
Min Burst:
Burst Trig:

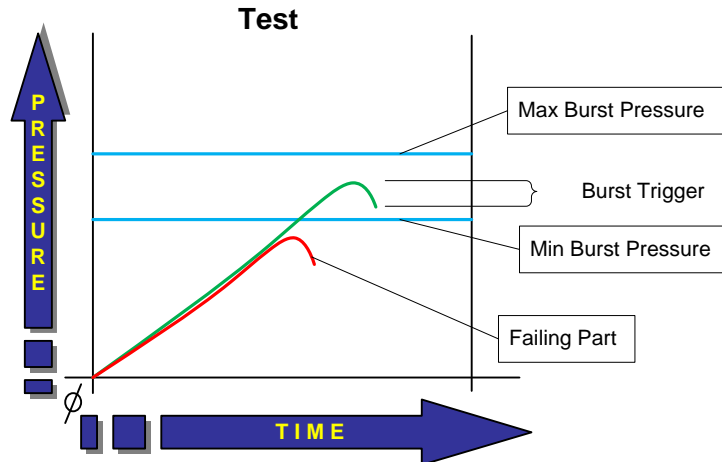

Occlusion

The occlusion test will check for blockages in the air flow path of a part. This test is similar in setup to a pressure decay test with two exceptions, first no settle step is used, and an occlusion test needs to see a large drop in pressure in the test step. The clamping output can be used to drive devices or pinch tooling to clamp off the part prior to test. During the test step these outputs can change states to allow the part to vent opposite to their filling location.

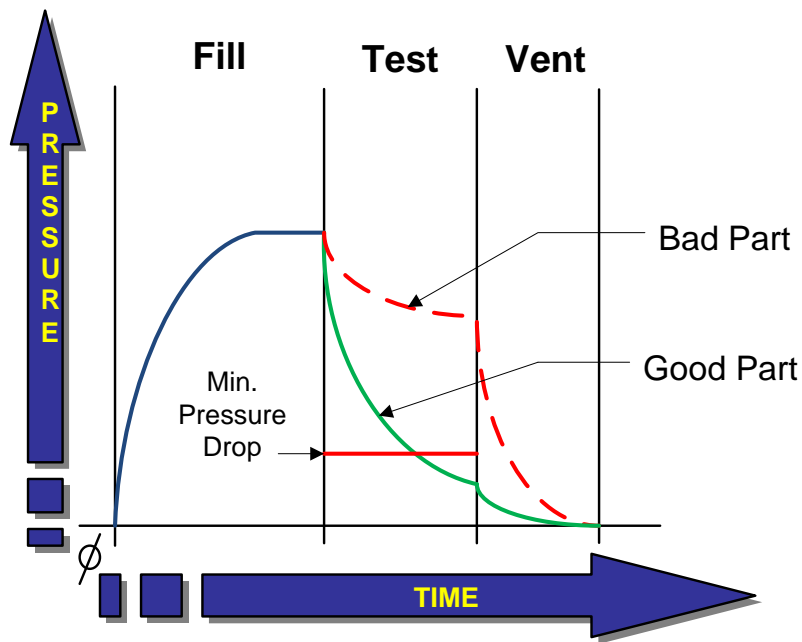

Crack

The crack test is similar to the burst test in that it finds the opening point of a device. But the crack is more sensitive to smaller opening pressures, or parts that weep open. A second pressure sensor is set on the downstream side of the part and monitors for the crack event. The downstream transducer can also be a mass flow sensor.

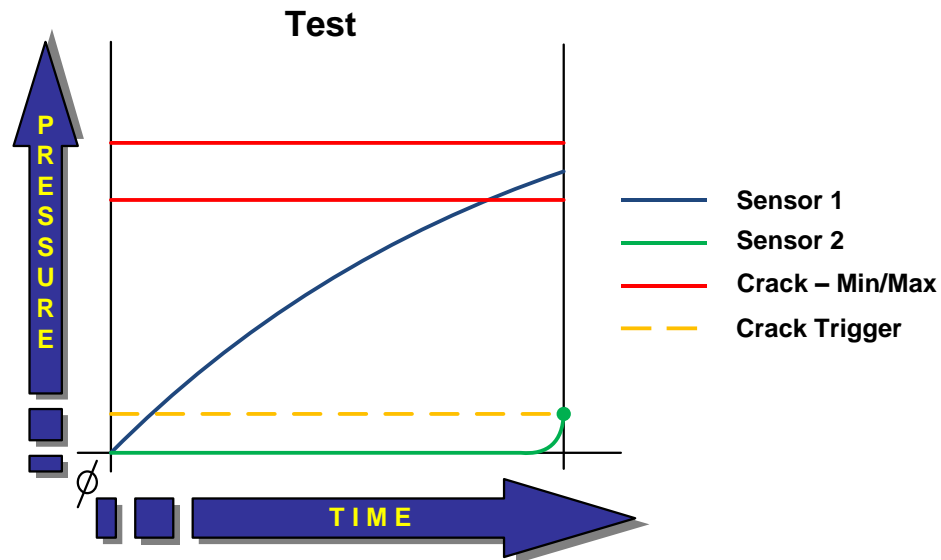

Test Tooling and Fixtures

To achieve accurate and repeatable results, units under test must be presented to the tester in the same fashion every time. The tooling must also be robust enough to withstand daily repeated use. The following are some key points to keep in mind in your tooling and fixture designs.

- Operator Safety
 - Zero-access, No pinch points
 - Ergonomically designed
 - Simple load/unload
- Material Selection
 - Stainless Steel
 - Anodized Aluminum
 - Delrin, etc.
- Sealing Forces
 - Exerted forces should not mask possible leaks
- Single or Multi-purpose
 - Should the tool be dedicated to a single task or fit multiple models?
- Size
 - How much production space do you have?
- Component Selection
 - Custom designed pieces or off-the-shelf technology?

Zaxis can deliver a complete turn-key system designed to your specifications.

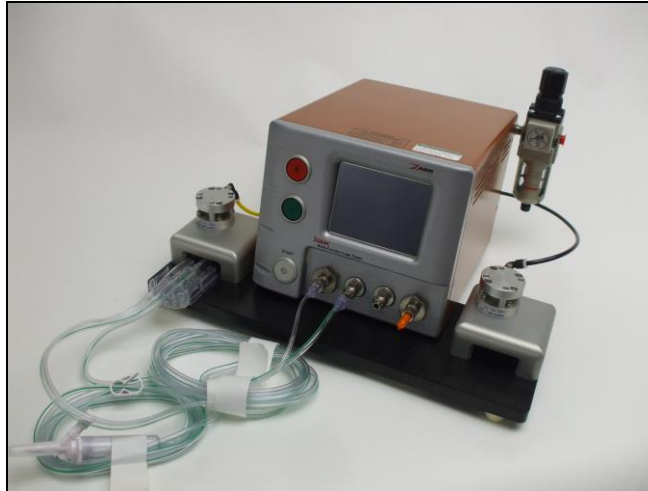

Pressure Decay and Occlusion pinch test fixture for a cassette with a tube set. (Two station)

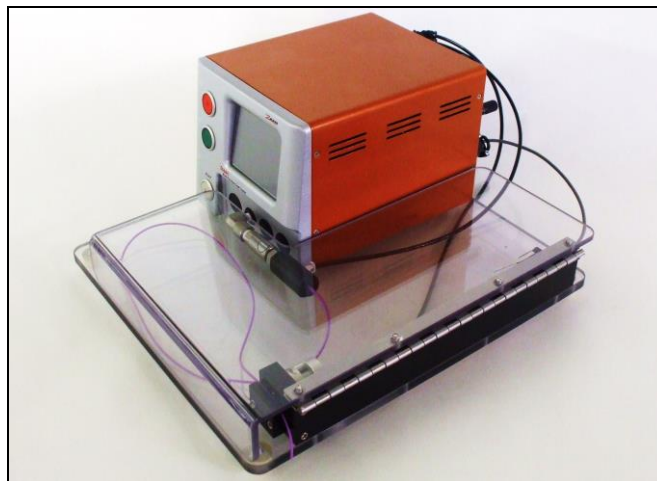

Pressure Decay, Mass Flow, and Burst test pinch fixture with shield and interlock for operator safety.

Engineering Data:

Converting Pressure to Flow Rate

You can determine the leak rate in flow units (cubic centimeters per minute) based on the pressures measured by Isaac. In a pressure decay test, Isaac holds the pressure drop on the main screen. The pressure drop is the delta pressure (ΔP) in the formula.

Delta time (Δt) is the test timer value set in Isaac's pressure decay program (provided the test passes). With this timer being set in seconds, simply divide by 60 to get the delta time in minutes.

Volume is the part volume plus Isaac's internal test circuit (approx. 1cc) plus the volume of connections between Isaac's test port and the product. The total volume (for our example) must be in cubic centimeters.

Atmosphere is the absolute barometric pressure in mbar (approx. 1000 mbar at sea level). This number changes with weather conditions.

$$\text{Leak Rate (cc/m)} = \frac{\Delta P \text{ (mbar)} \bullet \text{Volume (cc)}}{\Delta t \text{ (minutes)} \bullet \text{Atm (mbar)}}$$

- ΔP = Decay in pressure, value shown at end of test.
- Δt = Test step time in minutes.
- Volume = Volume of product and leak tester and any fixture volume.
- ATM = Atmosphere pressure in mbar absolute.

Physical Laws

We present here an abbreviated history and overview of fundamental laws dealing with pressure and flow measurement.

Pressure In physics, pressure is a force measured in terms of its distribution over a given area. This is expressed as force (F) divided by a unit area (A) of the surface area to which the force is applied. Air pressure most commonly refers to a force exerted uniformly in all directions. Force x Area = Pressure.

Absolute Pressure is pressure measured with respect to zero pressure (a very high vacuum).

Gauge Pressure is pressure measured with respect to surrounding air pressure (the pressure exerted by the weight of the atmosphere).

Barometric Pressure is the surrounding pressure caused by the atmosphere. At average sea level, barometric pressure is approximately 14.7 pounds per square inch, or 29.9 inches of mercury. This is equivalent to 101.3 Kilopascals.

Negative Pressure (Vacuum) Vacuum is defined as a volume void of matter. For practical purposes, this means a volume where as much matter as possible has been removed. A perfect vacuum does not exist even in the depths of space, where any given volume will probably contain one or more particles of matter or one or more units of energy, which is the equivalent of matter (Relativity). Even a vacuum with no measurable energy level is only a "virtual" vacuum.

Air Composition Our atmosphere is composed almost entirely of oxygen and nitrogen in their diatomic forms (two atoms bound together by chemical forces). Diatomic nitrogen makes up approximately 78% of the total molecules in the atmosphere. Diatomic oxygen represents nearly 21%. The inert noble gas, argon, accounts for about 0.9%, and the remaining 0.1% is composed of many trace gases, the most significant being carbon dioxide and water vapor. Water vapor is present in highly variable quantities ranging from 0 to 4% by volume.

Air Density If the atmosphere was like water and incompressible, pressure would decrease uniformly as you went up. In reality the atmosphere is compressible and density (mass per unit volume) is proportional to pressure. This relationship, call Boyle's Law, implies that density decreases with height in atmosphere: as height increases less mass remains above a given point; therefore less pressure is exerted. At sea level the density of air is about 1 kg per cubic meter (8 oz. per cubic foot). Both pressure and density decrease by about a factor of 10 for every 16 km (10 miles) increase in altitude.

Density does not depend solely on pressure. For a given pressure, density is inversely proportional to temperature. This relationship, known as Charles's Law, implies that the depth of an air column bounded by two constant-pressure surfaces will increase as the temperature in the column increases.

Density varies mostly with pressure over large vertical distances; at constant height, pressure variation with temperature becomes important. In the low atmosphere, air is heavy, with a stable mass of roughly one kilogram per cubic meter (1 oz/cubic foot). A room of 500 cubic meters (650 cubic yards) thus contains 0.05 metric ton of air. At an altitude of 3 km (2 miles), however, density is 30% less than at sea level.

This difference in air density can cause variations in flow readings from one location to another when elevations are quite different and no corrections are made.

Fluids vs. Solids The distinguishing feature of a fluid (gas or liquid), in contrast to a solid, is how easily the fluid can be deformed. If a shearing force, even a very small force, is applied to a fluid, the fluid will move and continue to move as long as the shear acts on it. For example, the force of gravity causes water poured from a cup to flow. Water continues to flow as long as the cup is tilted. If the cup is turned back up, the flow stops. The wall of the cup has balanced the forces.

Gas vs. Liquid Unlike liquids, gases cannot be poured as easily from one open container into another, but they deform under shear stress just the same. Because shear stresses result from relative motion, stresses are equivalent whether the fluid flows past a stationary object or the object moves through the fluid.

Although a fluid can deform easily under an applied force, the fluid's viscosity creates resistance to this force. The viscosity of gases, which is much less than that of liquids, increases slightly as the temperature increases, whereas that of liquids decreases when the temperature increases. Fluid mechanics is mostly concerned with Newtonian fluids, or those in which stress, viscosity, and rate of strain are linearly related.

Pressure and Density Pressure and density are considered mechanical properties of the fluid, although they are also thermodynamic properties related to the temperature and entropy of the fluid. For a small change in pressure, the density of a gas is essentially unaffected. For this reason, gas and all liquids can be considered incompressible. However, if density changes are significant in flow problems, then the flow must be considered compressible. Compressibility effects result when the speed of the flow approaches the speed of sound.

Fluid Flow—Real Fluids Equations concerning the flow of real fluids are complex. In turbulent flow, the equations are not completely known. Laminar flow is described by the Navier-Stokes equations, for which answers can be derived only in simple cases. Only by using large computers can answers be derived in more complex flow situations. Experimentation is still important for fully correlating theory with actual flow.

Laminar vs. Turbulent Flow When flow velocity increases, the flow becomes unstable, and changes from laminar to turbulent flow. In turbulent flow, gas particles start moving in highly irregular and difficult-to-predict paths. Eddies form and transfer momentum over distances varying from a few millimeters, as in controlled laboratory experiments, to several meters, as in a large room or other structure. Equations for turbulent flow are more complex than the formulas for laminar flow. For most answers, they require empirical relations derived from controlled experiments.

Whether a flow is laminar or turbulent generally can be determined by calculating the Reynolds number (Re) of the flow. The Reynolds number is the product of the density (designated by the Greek lower-case letter rho $\{\rho\}$), a characteristic length L , and a characteristic velocity v , all divided by the coefficient of viscosity (designated by the Greek lower-case letter mu $\{\mu\}$):

$$Re = (\rho) Lv/\mu.$$

Reynolds Number (Re) The Reynolds number has no unit of measure it is a pure number. As long as Reynolds number is small, the flow remains laminar. When the Reynolds number becomes greater than a critical value, the flow becomes turbulent. With ρ { ρ }, L , and μ { μ } constant, Re varies simply as velocity changes. For flow in smooth round pipes, critical value is about 2,000, with L equal to the diameter of the pipe.

Pascal's Law In 1653, Blaise Pascal came up with the idea that in a fluid at rest, the pressure on any surface exerts a force perpendicular to the surface and independent of the direction or orientation of the surface. Any added pressure applied to the fluid is transmitted equally to every point in the fluid. Pascal used his idea to invent the hydraulic press. Pascal's principle is often used in devices that multiply an applied force and transmit it to a point of application. Examples include the hydraulic jack, and the pneumatic cylinder.

Gas Law The actions of gases under varying conditions of temperature, pressure, and volume can be described and predicted by a set of equations, or gas laws. These laws were determined by measurements of actual gases and are valid for all substances in the gaseous state.

Measurements on gases were first published by Robert Boyle in 1660. He figured out that if an enclosed amount of gas is compressed until it is half its original volume while the temperature is kept constant, the pressure doubles.

Quantitatively, Boyle's Law is:

$$PV = \text{Constant}$$

Where the value of the constant depends on the temperature and the amount of gas present.

Jacques Charles studied relationships between the temperature and volume of gases, while maintaining a constant pressure. He saw a steady increase in volume as temperature increased, finding that for every degree Celsius rise in temperature, the gas volume increased by 1/273 of its volume at zero degrees C.

Charles's Law and Kelvin Temperature Charles's observations led to the absolute (Kelvin) temperature scale, since the gas, according to the equation, would have zero volume at -273 degrees C. Kelvin defined the absolute temperature scale so that absolute zero equals negative 273 degrees C and each absolute degree is the same size as a Celsius degree. The modern value for absolute zero is -273.15 degrees C. This temperature scale allows Charles's Law to be written $V/T = \text{Constant}$, where V is the volume of the gas, T is the temperature on the absolute scale, and the constant depends on the pressure and the amount of gas present.

In 1802, Joseph Guy-Lussac experimented with the relationships between pressure and temperature and came up with an equation a lot like Charles's Law: $P/T = \text{Constant}$.

Generalized Gas Law We can combine Boyle's, Charles's and Gay-Lussac's laws to express this generalized gas law:

$$PV/T = \text{Constant},$$

Where the value of the constant depends on the amount of gas present and t is the absolute (or Kelvin) temperature.

Ideal Gas Law The Generalized Gas Law can be written in a slightly different manner from the Generalized Gas Law:

$$PV = nRT$$

When written this way it is called the Ideal-Gas Law. **R** is the gas constant, and **n** is the number of moles of gas. The gas constant can be examined experimentally as $R = 0.082$ liter atm/Kelvin moles. Knowing **R**, the fourth variable can be evaluated if any three are known.

The gas laws are valid for most gases at moderate temperatures and pressures. At low temperatures and high pressures, gases deviate from the above laws because the molecules are moving slowly at low temperatures and they are closer together on the average at higher pressures.

Ideal vs. Real Gas Gases are typified as ideal or real. The ideal gas follows certain gas laws exactly, whereas a real gas closely follows these laws only at low density. Ideal behavior can be ascribed to a real gas if its molecules are separated by very large distances, so that intermolecular attraction is negligible.

Adiabatic Process (ad-ee-uh-bat-ik) Adiabatic compression and expansion are thermodynamic processes in which the pressure of a gas is increased or decreased without any exchange of heat energy with the surroundings. Any process that occurs without heat transfer is called an adiabatic process.

The adiabatic compression or expansion of a gas can occur if the gas is insulated from its surroundings or if the process takes place quickly enough to prevent any significant heat transfer. This is essentially the case in a number of important devices, including air compressors. An adiabatic expansion is usually accompanied by a decrease in the gas temperature. This can be observed in a common aerosol can, which becomes cold after some compressed gas is released. The reason for the temperature drop is that the gas is released too quickly to absorb any significant heat energy from its surroundings. Work performed in expanding the released gas drains some internal energy of the gas still in the can, making it colder. However, after the metal of the can becomes cold the process is no longer adiabatic. In a similar fashion, adiabatic compression usually increases the temperature of a gas, since work is done on the system by the surroundings. For example, when air is pumped into an automobile tire, the air temperature rises as a result of adiabatic compression.

Reference:

List of Terms and Where to find additional information

Abort a test, how to Press the red LED switch on the front panel. ABORT pops up in the status box telling you the process has stopped. An aborted test does not register on the tested or reject counters.

Atmosphere (1) in this guide, *atmosphere* means room air pressure. Atmospheric pressure is nearly synonymous with barometric pressure—an external force pushing on all sides of every object on earth’s surface. During a flow test, product being tested must flow into atmosphere, which causes a resistance to flow called back-pressure. Room atmosphere can change due to fluctuations in air conditioning or changing weather conditions. **(2)** The word *atmosphere* can refer to a unit of measure equal to pressure at average sea level. By convention, one atmosphere equals 1 bar. To say a test was taken at one atmosphere means the test was made at (or converted to) average sea level.

Barometric Pressure Also called atmospheric pressure. The force caused by the mass of air pressing down on the earth. Barometric pressure changes with elevation and weather conditions. Isaac’s regulator compensates for changes in barometric pressure to provide a constant relative output.

Bulkhead Fitting A connection passing through a panel or enclosure. One bulkhead on the back of Isaac is used for connecting the air supply to the tester. Bulkheads on the front are used for test and coupling ports. Standard bulkheads on the front have a 1/8” NPT female thread. Isaac offers a variety of bulkhead sizes.

Burst Test One of Isaac’s three possible operating modes in addition to pressure decay and flow. A burst test slowly fills a product through a flow control valve set by users. After the burst, pressure rapidly drops to near zero. Isaac captures the pressure immediately before the product ruptures or in some way opens to atmosphere. Burst mode is useful for testing pop-off valves, package seals, or devices that open to atmosphere after reaching a predetermined pressure.

Calibration Comparison of a device (such as Isaac) to a standard that is in turn calibrated to an even more accurate standard.

Calibration Data Values entered into Isaac through software calibration. Calibration data is stored as a look-up table in Isaac’s non-volatile RAM and is used to linearize pressure and flow transducer output at known pressures and flow rates.

Calibration Screen Calibration allows comparison of Isaac to pressure and flow standards. The calibration screen shows Isaac’s actual reading and the pre-programmed target value the technician compares to the pressure of flow standard. Only qualified technicians who have proper training and resources should calibrate Isaac.

Counters Isaac records the total number of tests performed (both pass and fail) and the number of rejects (fail only). Running totals are displayed in the *Test Cycles* and *Failures* fields on the Main screen.

Counters, (Reset) By selecting the "Cycles" or "Failures" numeric fields, the "Reset Counters" dialogue box will appear, press the clear button then press "OK".

Coupling Port The coupling port supplies air pressure to product sealing fixtures or other external pneumatic components. Generally, the port labeled "2" on front of Isaac is used for coupling air output.

Coupling Pressure The air pressure supplied to external fixtures. Coupling pressure must be the same as line or test pressure specified by the customer at order unless additional pneumatic components are added.

Coupling Time A delay timer used to apply a clamp or seal to product under test before the product is filled with air. Coupling time gives fixtures enough time to seal product before Isaac applies test pressure.

Crack Test a crack test is similar in function to a Burst test. Pressure is ramped on the upstream side of the part while the downstream side is monitored for an increase in pressure. When the specified pressure increase is reached, the test end and the ramped pressure is compared to limits for a Pass/Fail status. Crack tests are typically used when the part does not have a large event similar to a Burst, but has more of a weeping open.

Decay The amount of pressure a product can lose during a test period before going out of an established tolerance. Also called *pressure drop*.

Vent (Also called **Dump** or **Exhaust**) The final step in a test. The vent step is primarily used as a safety to vent any pressure away from the operator before removal of the test part. Disabling the Vent will not affect the test result. After Isaac completes a test, the vent valve is activated to open the product into Isaac's internal chamber. If a vent step is not required (for instance if you want to unplug product to vent pressure), set the Vent timer to 0.0 and uncheck the Auto box.

Event The pressure change that signals the change in the device under tests condition. This trigger is used to end the test and compare the pressure reading to the limit settings for pass/fail status.

Fail Light Isaac's red indicator with an X-mark. The fail light turns on whenever a test exceeds established parameters.

Pre-Fill Isaac option that allows the unit under test to be filled at a quicker rate than through the test circuit.

Firmware The set of instructions stored in programmable read-only memory (Flash) that controls Isaac's operation. *Firmware cannot be altered by the customer.*

Firmware Version (How to find) the version of firmware running Isaac is displayed on the 'About' screen.

Fixturing A fixture is a device connected externally to Isaac. Fixtures can be mechanical, electrical, pneumatic, or combinations of all. Typical fixtures are pneumatic clamps that seal products during a pressure decay or flow test. Isaac can supply air from the coupling port to operate pneumatic fixtures. Customers must specify at the time of order whether they want coupling pressure to be line or test pressure. Many fixturing options are possible.

Flow Control Isaac has a built-in flow control to provide a slow pressure increase (ramp up) needed for burst and crack testing. Users can precisely set the flow control for the exact pressure build-up required for the product to be tested. After the flow control is set for a particular product, further adjustment of the needle valve is unnecessary.

Flow Standard 1) A measuring instrument or certified restrictor that can be connected to Isaac as part of a flow calibration. The flow standard must have adequate accuracy, stability, and repeatability needed to calibrate Isaac. The flow standard must have current calibration documentation if the customer requires accuracy traceability. 2) A calibrated device to challenge the tester on an as needed basis. This device is calibrated and traceable. For example a daily verification can be done to ensure the tester will still find the required flow value.

Flow The amount of air passing through an object measured in cubic centimeters or liters per time period (second, minute or hour) at a given pressure.

Flow Transducer A device that converts gas flow into electrical signals. The type of transducer used in Isaac is a mass flow transducer, which is both accurate and immune to room temperature fluctuations.

Flow Test A flow test involves pushing air through a product at a set pressure and measuring the resultant flow with a flow sensor. Flow testing can be used in two ways--

- (1) Flow Leak Detection. Product is filled with air at a set pressure and then sealed from atmosphere as in a pressure decay test. Any flow above zero indicates a leak.
- (2) Flow Measurement. Air is pushed through a product at a set pressure and allowed to flow to atmosphere. A flow sensor measures the volume of air moving through the unit under test. Isaac's digital readout shows flow rate in customer selectable units.

Foot Switch An optional switch that connects to the back of Isaac that the operator can use to start a test cycle. This switch has the same function as the **START** button on the front of the Isaac.

Gage Pressure A force referenced to barometric pressure. Isaac uses a gage regulator to keep the pressure constant as barometric pressure changes.

Gross Leak A leak that causes a drop below the test pressure minus the pressure tolerance in the settle step.

Interface Communication between Isaac and a peripheral device such as a computer or printer. Isaac has four interfaces, a serial protocol known as RS232 to communicate, an Ethernet port, discrete I/O points, and a footswitch connector.

I/O (Input/Output) Connections used Isaac to communicate with computers or Programmable Logic Controllers (PLCs). Isaac I/O includes inputs to change and start programs and output pass/fail status.

Isaac In this guide, the word Isaac refers to the base-model Isaac leak tester. Your particular tester is based on the Isaac leak tester and most of the contents of this guide apply.

LCD Abbreviation for liquid crystal display. Isaac's display is a LCD device that provides setup prompts, menu options, test results, and other system information.

Leak Rate A pressure drop over time can be stated as a leak rate. For example—0.1 mbar per second is a leak rate. A leak rate can also be stated in flow units such as 4 cc/minute.

Leak Test See *Pressure Decay Test, Flow Test*.

Link Programs, how to In the *Program Screen* select the *Next Prog:* field, press the *Clear* button and enter the program number you want to link. Press *Enter*. If no link is desired set this field to the same program number.

Looped Programs to run a test multiple times enter a value in the Loops box, this will be the number of test iterations ran with no pause between tests.

Main Digital Screen This readout shows the pressure and flow values during pressure decay flow and burst testing. The way the main digital screen functions, varies with each testing mode.

Measurement Units See *Units of Measure*.

Menu A menu is a list of setup or programming options. See also *Setup Screen*.

Modes Isaac has multiple operating modes: (e.g. pressure decay, flow, and burst) Isaac shows the current mode in the test type box on Isaac's *Main* screen.

Operator The person who connects products to Isaac, presses the **START** button, and monitors the system while under test. For the purposes of this guide, the operator is separate from the user. Users typically handle Isaac's setup and programming.

Pass Light Isaac's green indicator with check mark. The pass light turns on after the tester completes a test that remains within established parameters.

Pilot Air Certain applications require the use of pneumatics that is pilot actuated. A steady air supply is required to assist in the operation of these valves. Zaxis' proprietary air valve requires 85-100psi to function correctly.

Program Screen This screen is used to enter all setpoints and limits concerning pressure decay, flow, and burst test. Different modes require varying setup information. The program screen changes depending on the type (or mode) of test being programmed. The program screen has a header that tells you the program number for which you are currently setting parameters.

Pressure Decay Test Pressure decay testing is used to test products for leaks by trapping pressure inside and then measuring pressure loss. The abbreviation *PD* is often used in this guide to refer to pressure decay.

Pressure Tolerance, The plus or minus allowable change in the test pressure. If the pressure fails to achieve this amount during the Fill step a "LO Pressure" error will report. If the pressure exceeds this mark during the Fill step a "HI Pressure" error will report. If the test pressure falls below the mark during the Settle step, a "Gross Leak" error will report.

Pressure Regulator Isaac uses a precision pressure regulator that controls line pressure. The pressure regulator is adjusted during setup to set test pressure.

Pressure Standard A precision measuring instrument that can be connected to Isaac as part of a pressure or flow calibration. The pressure standard must have the required accuracy, stability, and repeatability to measure Isaac's output. The pressure standard must have current calibration documentation if the customer needs to prove accuracy traceability.

Pressure The relative force of a compressed air or gas. Isaac is generally configured to use psig, which is the force of compressed gas relative to barometric pressure. Alternatively, mbar (millibar of 1/1000 bar) , mmHg (millimeters of mercury), inH₂O (inches of water) or kPa (Kilo Pascal) may be selected.

Pressure Transducer An electro-mechanical device (also called a sensor) that converts pneumatic pressure into electrical signals. Isaac's pressure transducers are rugged, accurate, repeatable, and have a very low internal volume.

Programs Data (such as test pressure, test time, and reject levels) entered by the user and stored in Isaac's FLASH RAM (Non-volatile). A program is setup in Isaacs *Program* screen. The **Isaac has 100 test programs.**

Ramp To slowly increase pressure by routing test pressure through the flow control valve located on back of Isaac. Various ramp rates can be established by adjusting Isaac's built-in flow control.

Reject Level The amount of pressure drop allowed in a pressure decay test. This value is set in the program setup screen. The reject level, together with test time, determines the amount of acceptable leak rate.

RS232 A standard serial communications protocol used by most computers and computer peripherals. Isaac uses an RS232 protocol to send test result data to printers and computers.

SCCM Abbreviation for Standard Cubic Centimeters per Minute. This is a flow measurement standardized to 68 degrees Fahrenheit and 14.7 psi (average sea level).

Set point A programmable threshold value (usually a minimum and maximum value) used to establish a testing tolerance.

Settle A time interval following fill phase that allows product to stabilize before Isaac starts the measurement phase. Longer settle times are often required in products constructed of flexible materials.

Start Switch The round red center lit silver pushbutton located to the left of the test ports. This button serves as a start and abort button for the test.

Stored Programs A set of instructions (parameters) that can be set by the customer to run a variety of tests. Users can alter stored programs to meet specific product testing needs. Programs are configured in Isaac's *Program* screen and are kept in NVRAM (Non-volatile.)

Supply Air Compressed air or gas connected to the rear fitting labeled *Supply*. Isaac's standard fitting is a 1/8" NPT (Similar to R1/8 BSPT British Standard Pipe Taper) female thread bulkhead. Air must be clean, dry, and free of oil

Target A preprogrammed number that Zaxis stores in firmware used to calibrate Isaac's pressure and flow sensors. The target value is matched to a pressure or flows standard to create a lookup table for sensor linearity adjustment.

Test Circuit The pneumatic tubing, fittings, valves, and sensors that make up Isaac's internal air passages. The volume of gas trapped inside the pressure decay test circuit is about 1.0 cubic centimeter.

Test Cycle A test cycle is all Isaac-controlled testing activities that occur from the time the **START** switch is pressed to the time the operator removes the tested product. One test cycle can have multiple tests by linking programs in Isaac's *Program* screen. Multiple tests in one test cycle are sometimes called a test series.

Test Phases The three testing modes (decay, flow, and burst) each have individual phases or intervals of testing. Pressure decay has four possible time intervals that can be set: coupling, fill, settle, and test. A flow test has three phases: coupling, fill, and test. A burst test has just two possible phases: coupling and test.

Test Port The bulkhead fitting (or fittings) on Isaac's front panel. The product to be tested is connected to the test port. From the test port, Isaac can supply positive pressure or vacuum for a variety of leak and flow test. Customized Isaacs could have multiple test ports. See *Bulkhead*.

Test Pressure Test pressure is the level of air pressure used to inflate product under test. Test pressure is set by adjusting the regulator on the rear panel of Isaac. Test pressure can only be set if Isaac has supply air connected to the back fitting, and the output port is blocked with a leak-tight cap.

Test Pressure Info Box An area on the *Main* screen that shows pressure values depending on test type (decay, flow, or burst), and depending on what phase the test is in.

In a pressure decay test, this info box shows the preset test pressure (set with the regulator) during coupling phase. It shows actual applied pressure during the fill and settle phase. In test phase, the info box shows the last reading made during the settle phase.

In a flow test, the pressure box shows preset test pressure during coupling time. In fill and test times, it shows actual applied pressure, and holds the last pressure reading made at the end of test phase.

In burst, preset pressure is displayed during coupling and test times.

Timers Isaac uses microprocessor timers to establish time intervals for a variety of test functions. Time values are set in Isaac's *Program* screen by the user to control coupling time, fill time, settle time, and test time. Timers are calibrated in seconds with a maximum setting of 999.9 seconds. See *Program Screen*.

Isaac^{HD}

Units of Measure Isaac can display pressure, flow, and time in several user-selectable measurement units. Changing units of measure is made through the *Setup* screen.

Valves Isaac contains modular solenoid valve blocks that direct the flow of air (or other gas) through measurement circuits. The number, type, and arrangement of valves in an Isaac tester can be customized for special applications.

Maintenance/Troubleshooting



Warning! Disconnect power before servicing the unit.

Special Precautions

If at any time the cover is removed from the tester for service, verify that the flex-ribbons connecting the display to the main PCB (printed circuit board) and the main PCB to the I/O are seated and are square to the connectors. Out of alignment flex ribbons will cause damage to the PCB.

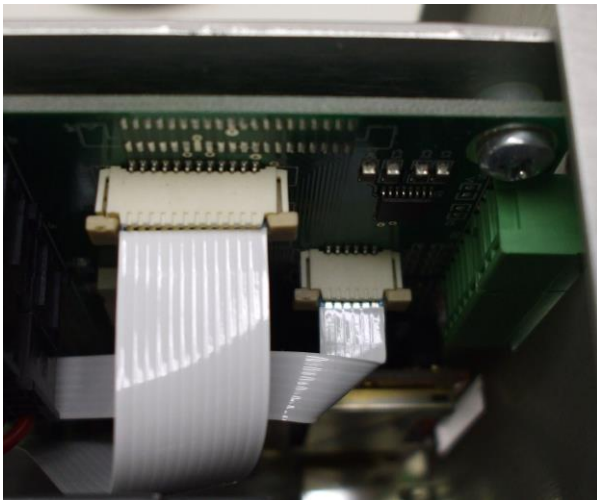

Flex cables installed correctly.

Internal Leaks

At the factory a baseline leak test is performed to verify leak-tightness and functionality. This test is a good indicator of an internal leak. The parameters are listed below.

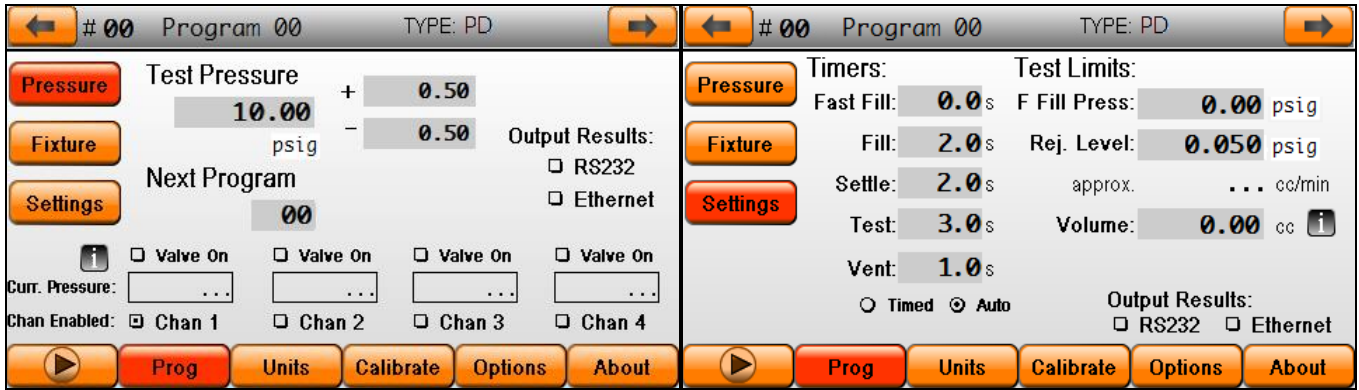

Running a capped port test with these parameters should yield a decay value less than 0.005psig (0.344mbar).

Valve manifold (removed from machine for clarity)

Type 1 Valve Manifold

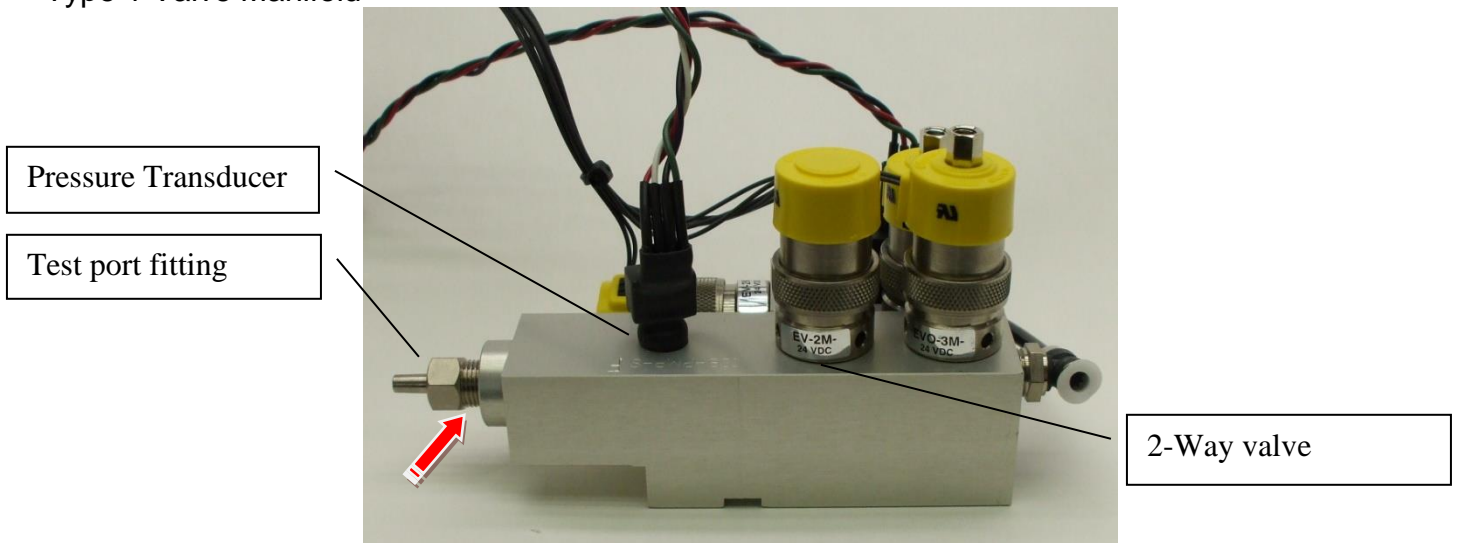

The most common place for leaks to occur is at the junction of the test port fitting to the valve manifold.

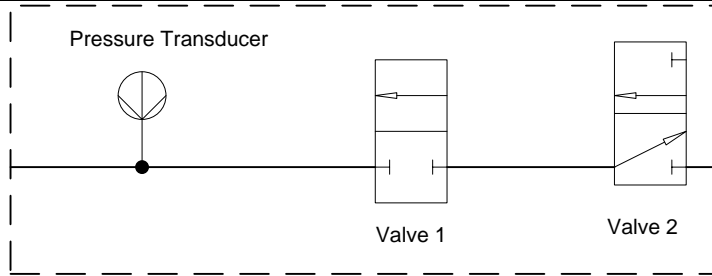

Pneumatic Diagram

When the test pressure is vented, the airflow path is through Valve 1 (on) and out to atmosphere through Valve 2 (off).

Debris from test parts or dirty air can be trapped between the spider seal and valve seat of the 2-Way valve, holding the valve in an open position.

Valve Cleaning

Debris from test parts or dirty incoming air can be trapped in the 2-Way valve, holding the valve in an open position.

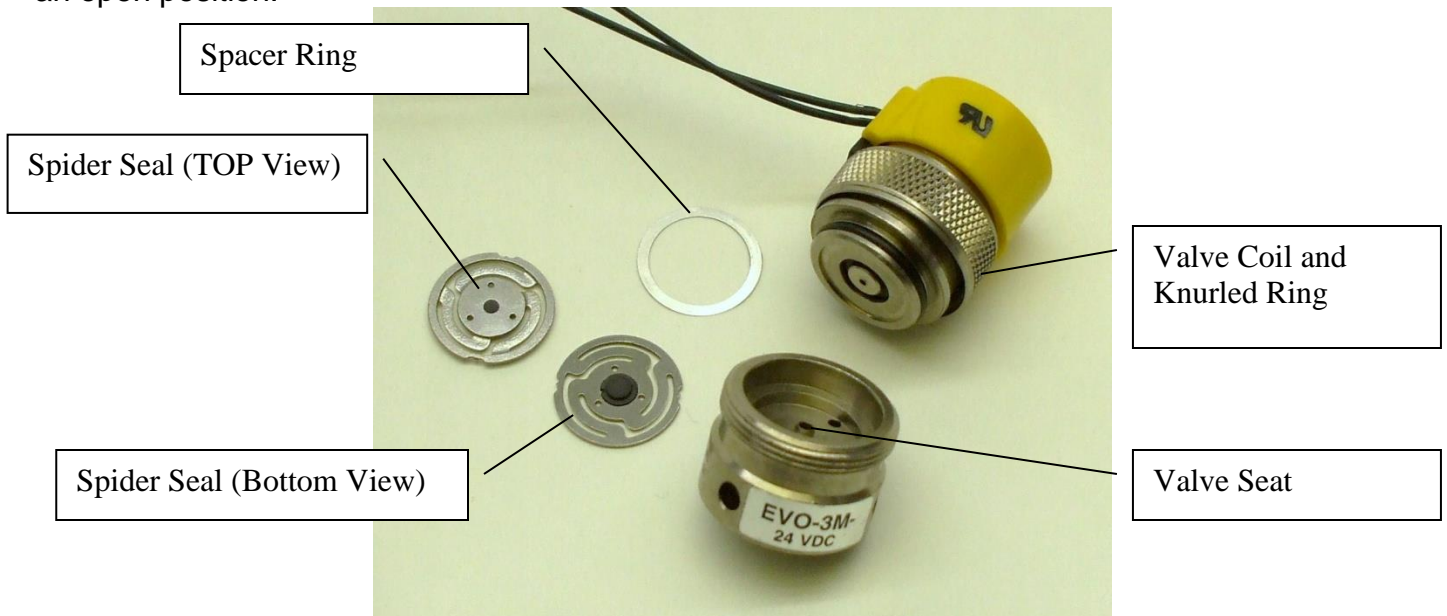

The valve is accessed by loosening the knurled ring in the center of the valve counter-clockwise. Once separated the spider seal and spacer ring can be removed to inspect the valve seat and surrounding area for debris. The spider seal could also hold debris.

The valve is re-assembled by placing the spider seal into the lower section of the valve with the bottom facing the valve seat, followed by the spacer ring, and lastly the valve coil is pressed into the lower section secured by the knurled ring.

Valve manifold (removed from machine for clarity, removal of manifold is not necessary for cleaning or inspection)

Type 2 Valve Manifold

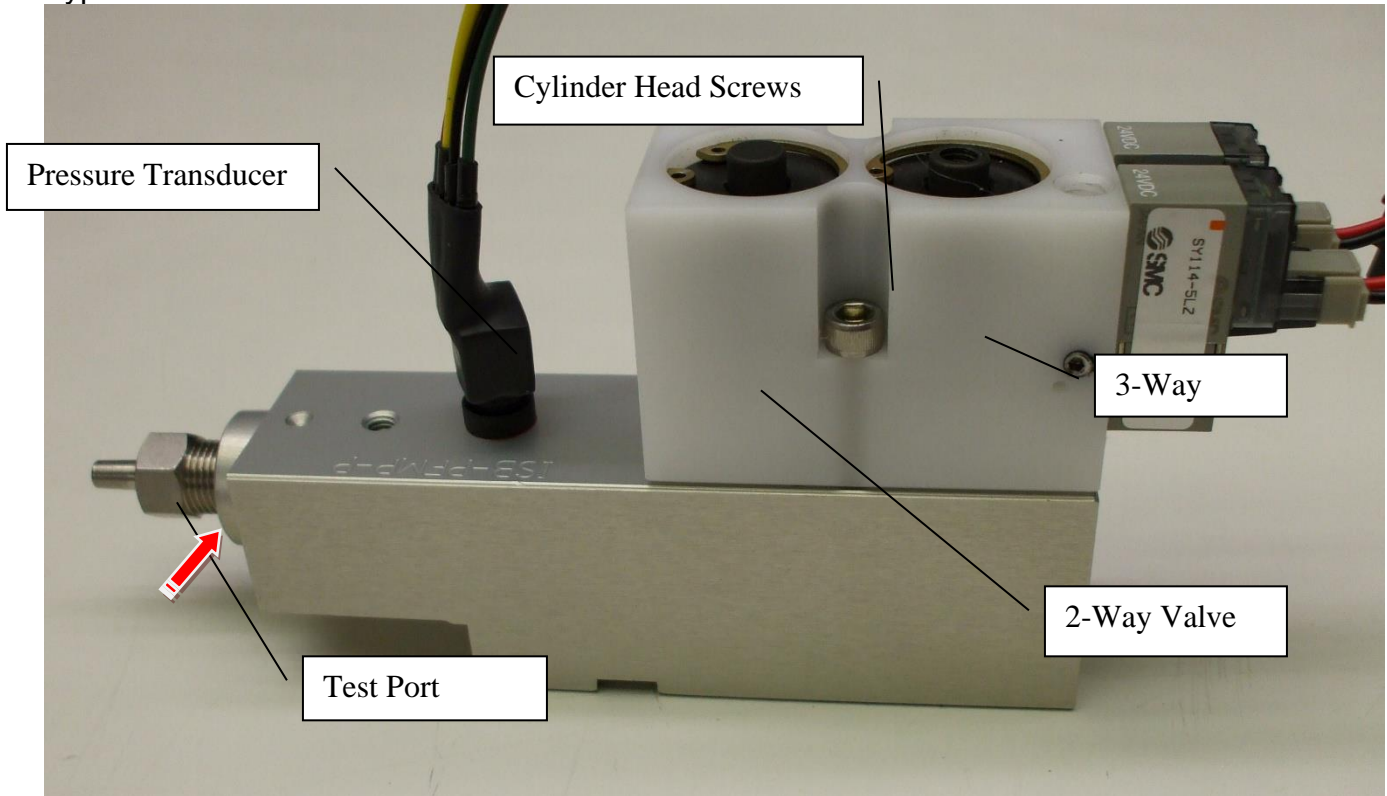

The most common place for leaks to occur is at the junction of the test port fitting to the valve manifold.

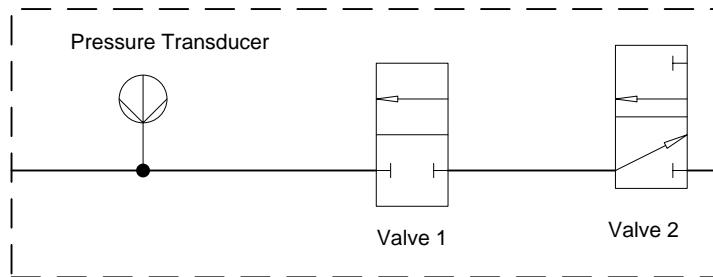

Pneumatic Diagram

When the test pressure is vented, the airflow path is through Valve 1 (on) and out to atmosphere through Valve 2 (off).

Debris from test parts or dirty air can be trapped under the piston of the 2-Way valve, holding the valve in an open position.

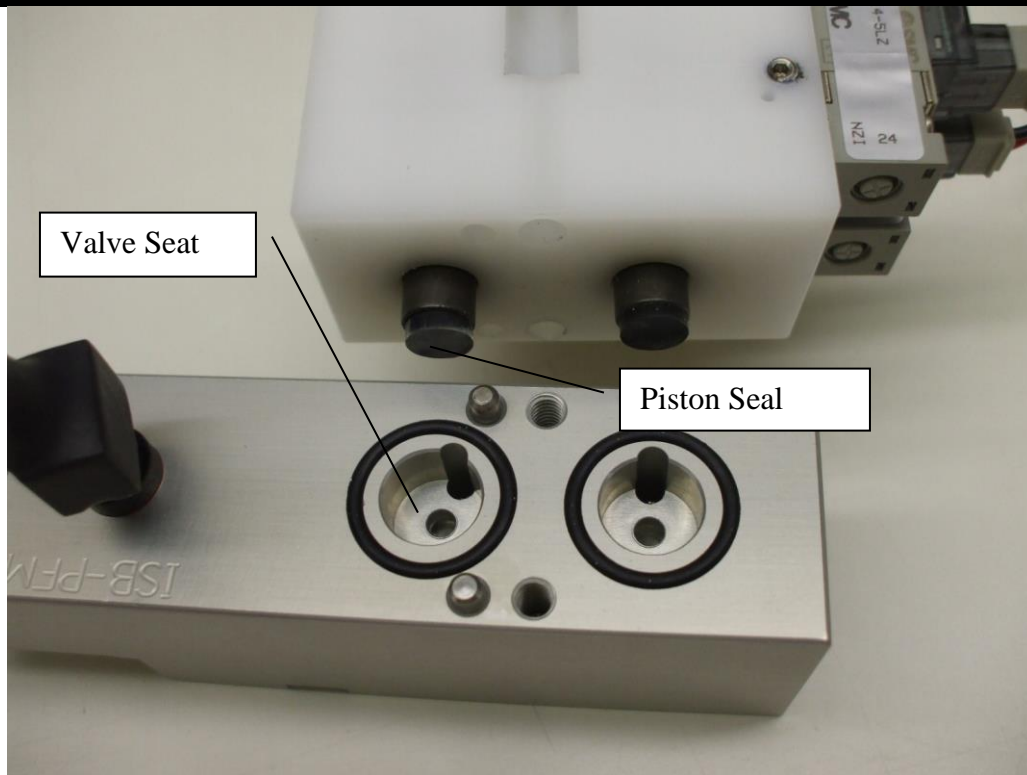

To clean debris from the valves, remove both cylinder head screws. The cylinder head and manifold body will separate. Check and clean for debris on both the valve seat and piston seal face.

To re-assemble, verify the manifold body o-rings are in place, replace the cylinder head on the manifold, (pins will aid in alignment). Tighten the cylinder head screws, making sure not to over tighten or strip the screw. The cylinder head should be flush to the manifold body.

Filtration

If a mist separator filter was purchased, the filter media can be inspected and cleaned. Some units will have a regulator/filter combination. Disassembly of the filter portion is identical.

The filter size is 5 micron.

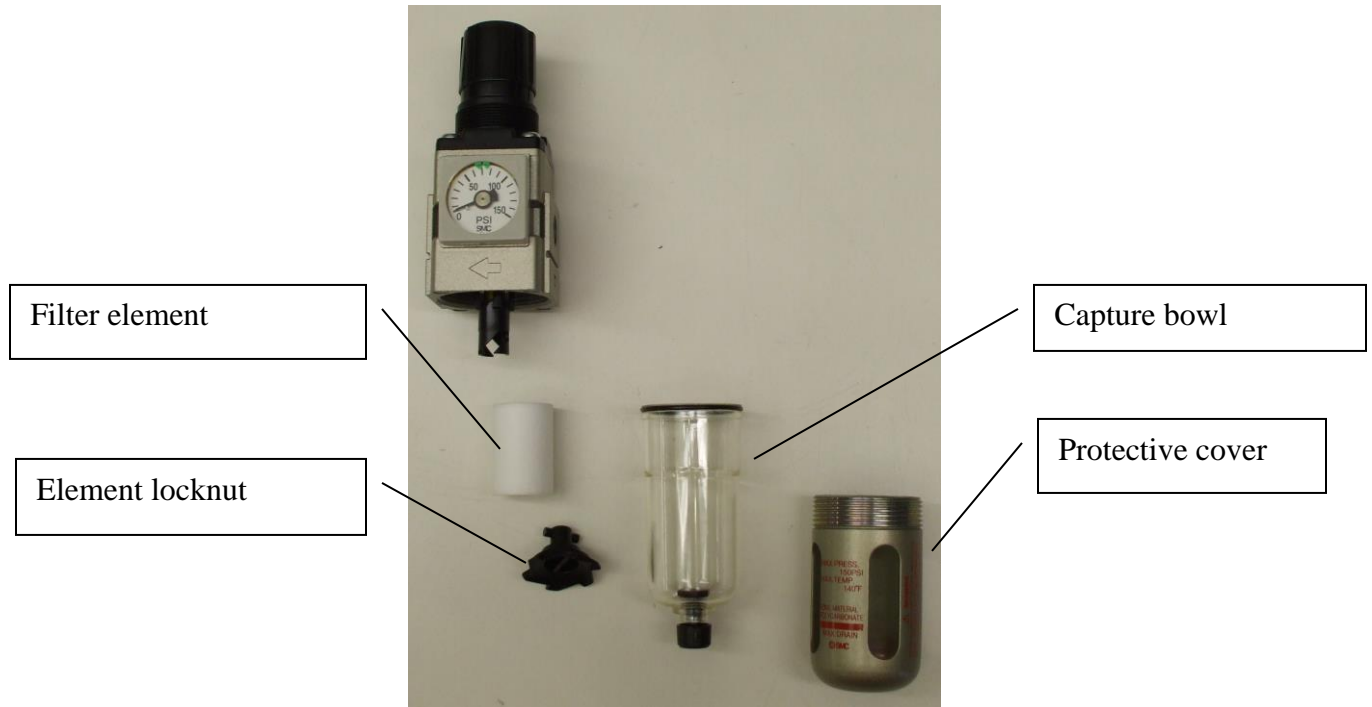

Fuse



Warning! Disconnect power before removing fuse holder.

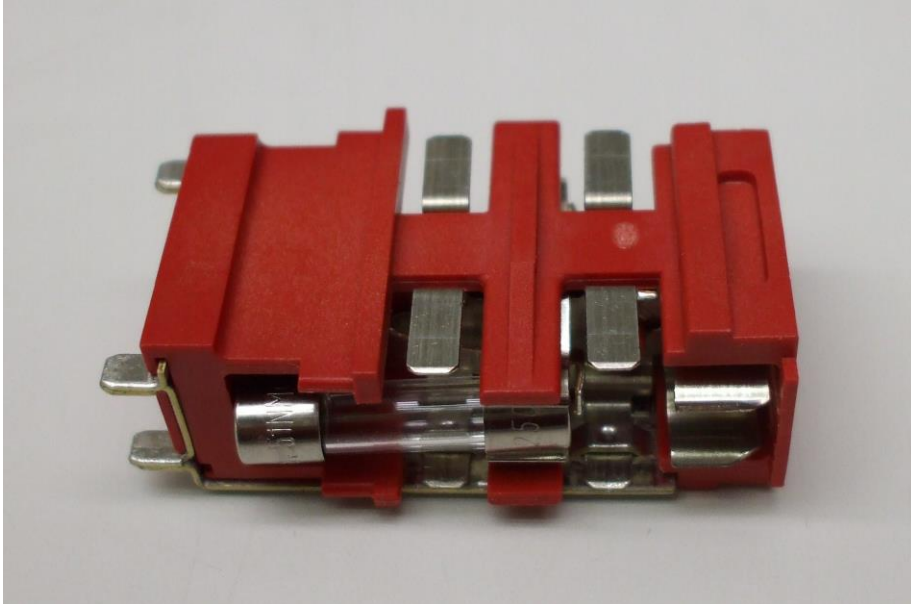

The installed fuses are: 5 X 20mm, 250V F 2.0A. Both line and neutral are fused. The fuse should be seated towards the insertion end of the cradle (as shown, typ. 2plcs).