

Isaac

Multi-Function Leak Tester

The Problem

When a high yield production part must be tested, the need for flexibility in testing is often required.

High production output, and tight manufacturing schedules require the use of multiple testing stations. Each testing station takes up valuable clean room or production line real-estate and can require extra personnel.

Most low cost bench top testers can not be configured to provide such flexibility. In the past only large scale systems were available to meet this need. To setup these large units the programming can be complex and confusing.

The Zaxis Solution

The Isaac series of testers have the flexibility to offer multiple ports of concurrent or sequential testing with a straight forward user interface.

Offered in 2, 3, and 4 port configurations the Isaac concurrent tester allows multiple parts to be tested at the same time.



How the Isaac Works

The Isaac concurrent pressure decay tester works like this:

1. The product is attached to the test ports and the test sequence is initiated.
2. The **Fill** step, pressurizes the part with regulated air through all valves.
3. The valves are closed and the part is allowed to **Settle**. Trapping air between odd number valves and the product.
4. During the **Test** step the decay of pressure is measured by the Isaac's pressure sensors[S1-S4].
5. If a product exceeds the programmed reject value a reject indicator will be given along with the decay value for each channel.
6. A part that does not decay past the reject value is a good part.
7. The remaining pressure is **Vented** for safety. Odd number valves open to allow the pressure to vent back through the even numbered valves.

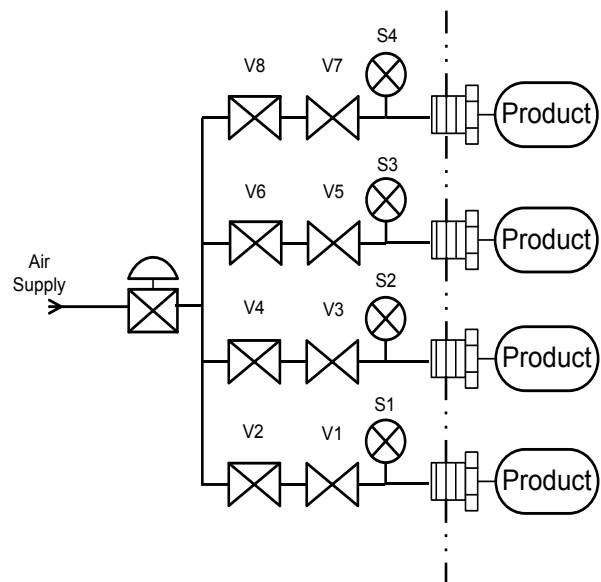

Leak Rate Calculation

To calculate leak rate, the total volume of both the products under test and the instrument test circuit must be included in the formula. The leak rate formula below excludes minor variables such as temperature change and part compliance.

$$\text{Leak rate (sccm)} = \Delta p / \Delta t * V / \text{atm}$$

atm = Atmospheric pressure (psia)

V = Test volume (cm³)

Δp = The decay in pressure during test time (psig)

Δt = The amount of decay time (min.)

For example:

$$\text{Leak rate} = .02\text{psi}/0.05\text{min} * 50\text{cm}^3/14.7\text{psia}$$

$$\text{Leak rate} = 0.4 * 3.401$$

$$\text{Leak rate} = 1.36 \text{ sccm}$$

Isaac Display

Channel	Decay Results	Test Pressure	Test Result
1	0.0001	10.02 psig	Pass
2	0.0159	9.98 psig	Leak
3	0.0001	10.00 psig	Pass
4	0.0050	10.00 psig	Pass

Channel numbers

Decay Results

Test Pressure

Test Result

Applications

Isaac pressure decay testers are used frequently to test parts that were tested using simple analog pressure gauges or tested by looking for bubbles in a dunk tank.

The Isaac can be used to test both small and large volume parts. For small parts the extremely small internal volume will allow for very low test times allowing a high throughput of production. If a large part is to be tested, the pneumatics can be adjusted to maximize the potential of the tester.

Both rigid and flexible parts can be tested, making the Isaac the most flexible platform available.

Features

- High Sensitivity
- Extremely low internal volume (0.8cm³)
- Small footprint.
- Available in a wide range of test pressures.
- Off the shelf delivery.
- Custom testing capabilities..
- Easily adapted to automation.
- Intuitive user interface.
- Simple calibration procedures.

